











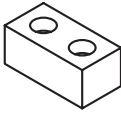

Sliding Glass Door Corner Meet Assembly Instructions

SERIES 670/770

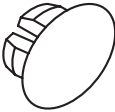

CUSTOM WINDOWS + DOORS

670/770 Parts List

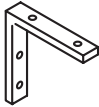
PARTS		
DESCRIPTION	PARTS BAG QTY.	
 <p>FRAME ASS'Y SCREW #8 x 1" LONG</p>	16 per bag	
Screw used to assemble the main frame.		
 <p>JAMB BUMPER SCREW #6 x 3/8" LONG</p>	1 per bumper	
Screw used to attach the jamb bumper to the operable panel.		
 <p>COME - A - LONG SCREW #8 x 1 1/4" LONG</p>	2 per come - a - long	
Screw used to attach the come -a- long block to each operable panels.		
 <p>4 HOLE BUMPER STOP SCREW #8 x 3/8" LONG</p>	4 per bumper	
Screw used to attach the 4 hole bumper stop to sill and head.		
 <p>COME - A - LONG AND COVER</p>	1 per operable panel	
Used on the top of operable panels at interlock. Used on multi panel configurations only.		
 <p>SCREEN KEEPER SPACER</p>	1 per screen keeper	
Shim used to raise screen keeper off of frame for additional adjustment.		
 <p>HEAVY DUTY 4 HOLE BUMPER STOP</p>	2 per operable panel	
Reinforced vinyl stop attaches to header & sill of the main frame. Used to prevent the "X" panel from impacting components adjacent to it. Also prevents pocket panels from rolling off the track.		
 <p>FIXED PANEL CLIP (6" LONG)</p>	1 per "O" panel	
An aluminum clip that attaches to the panel stile & main frame jamb. Used to fix the "O" panel in place.		
 <p>FIXED PANEL RETAINERS</p>	2 per "O" panel	
There are 2 different retaining clips., one for fixed panels that are on the inner most track of the home (Track 1) and one for fixed panels that are on all other tracks.		
 <p>SCREEN LATCH KEEPER</p>	1 per operable screen	
Screen latch keeper is used with the standard panel pull on the box screen. Attaches to the main frame jamb to allow the screen to lock in to the jamb.		
 <p>ROLLER ADJUST HOLE PLUG</p>	2 per panel	
Round plug used to fill the hole for the adjustment screw on the rollers.		
 <p>JAMB BUMPER</p>	1 per main frame jamb	
Attached to the stile. It keeps the panel from making contact with the main frame.		
 <p>DUST PLUG (HIGH)</p>	2 at each interlock connection	
Used on the main frame at the top / bottom of every operable panel interlock connection.		
 <p>"O" PANEL BRACKET High-Performance Doors Only</p>	1 per fixed panel	
Used to fix the "O" Panels to the Head Only.		

670/770 Parts List

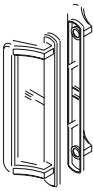
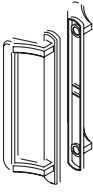
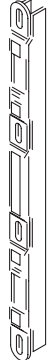
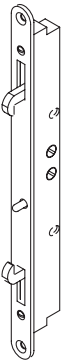
PARTS			
DESCRIPTION		PARTS BAG QTY.	DESCRIPTION
	MORTISE LOCK RAISED HANDLE SET (ACTIVE)	1 per lockstile panel	RECESSED LOCK (ACTIVE)
	<p>Standard handle set provided to lock the door. Handle set comes complete with two metal handles, one on the interior & one on the exterior with color match screws.</p>		<p>Optional handle set provided to lock the door. Comes complete with two metal handles, one on the interior & one on the exterior with color match screws.</p> <p>* Also used as secondary locks when recessed locks are ordered as Primary Locks.</p>
	MORTISE LOCK RAISED HANDLE SET (INACTIVE)	1 per astragal	RECESSED LOCK (INACTIVE)
	<p>Used with Standard raised handle set when door has Astragal panels. Comes complete with two metal handles, one on the interior & one on the exterior with color match screws. Not used on OXO configurations.</p>		<p>Used with recessed handle set when door has Astragal panels. Comes complete with two metal handles, one on the interior & one on the exterior with color match screws.</p>
	1" MORTISE LOCK KEEPER	1 per Mortise latch	SECONDARY LOCK THUMBTURN
	<p>The lock keeper is placed on the main frame jamb or the astragal. This allows the panel to lock into the main frame or lock into the astragal panel.</p>		<p>Optional secondary lock used with Mortise Raised handle set.</p>
	MORTISE LATCH	1 per Mortise latch	EXTERIOR FLATPLATE
	<p>Factory installed dual point Mortise Latch used to lock the doors.</p>		<p>Used with Interior Raised handle set when a low profile is needed on the Exterior.</p> <p>* Will not be anything to grab to hold the doors.</p>
<p>BAG MAY BE SENT WITH EXTRA PARTS TO ACCOUNT FOR LOSS OR MISPLACEMENT OF SMALL PIECES.</p>			
<p>PLEASE MAKE SURE PRIOR TO ASSEMBLY THAT YOU HAVE THE CORRECT AMOUNT OF PARTS CALLED OUT FOR BY THE "PARTS BAG QTY" SECTION.</p>			

NOTICE

CAREFULLY FOLLOWING THE INSTRUCTIONS IN THE PROPER SEQUENCE WILL REDUCE MISTAKES AND SAVE TIME.

- Protect mainframe only with light coating of oil, grease or soap. Action of lime in plaster can destroy finish.
- Sill must be smooth ... buff edges and fill any valleys left by mason. A ridge or lump could cause latching problems.
- If installed in wood surround, measure assembled door frame, add shim space and make surround to these dimensions.
- A Parts List is provided at the front of this document for quick reference. Inspect the product and take inventory of all parts and pieces prior to installation. (ex. screws, frame, panel, etc.)
- Exploded View Reference(s) at the front of this document act as a reference for general location of parts and depict figures that are referenced when following steps outlined in these instructions.
- Carefully review these assembly instructions along with installation details contained in the AAMA Specifications, Miami-Dade Notice of Approval, or test reports, including anchorage information, if applicable.

SECTION 1: CORNER DOOR SECTION

Corner door main frames will meet at a 90° corner (either inside or outside) (See Figure 1)

Each side will either be a by-pass or a pocket and will follow the same main frame instruction as listed in the appropriate by-pass or pocket frame assembly sections.

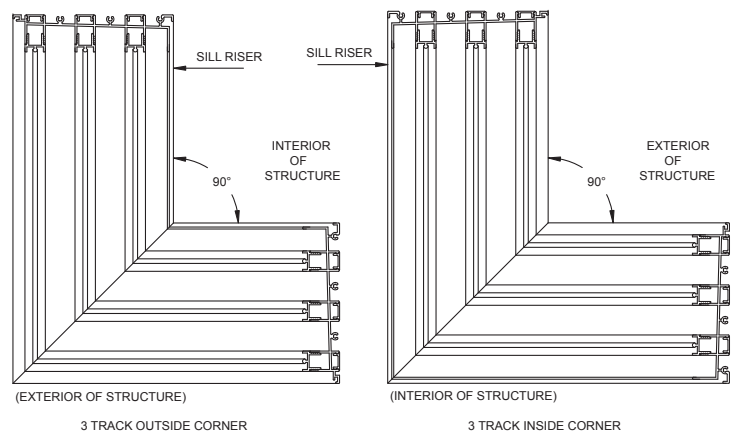

Figures 1

SECTION 2: FRAME ASSEMBLY

If unit being installed has only pocket doors, skip to the pocket door section.

1. Gather the main frame header, sill and jamb.
Trace the frames ends with sealant. (See Figure 2)

Note: It is good practice to seal the outside of all joints heavily after the frame is assembled.

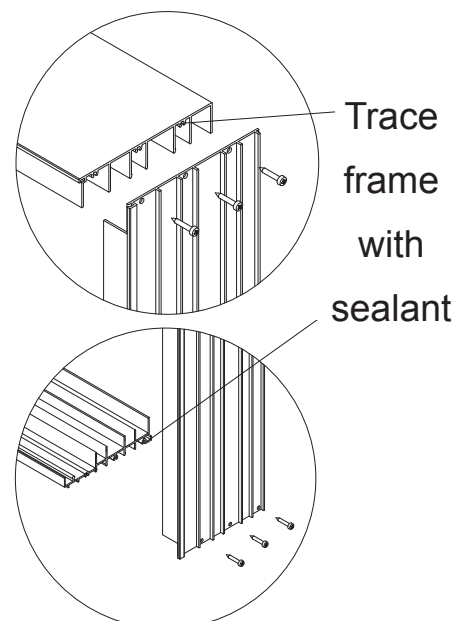

Figure 2

2. Assemble mainframe head, jamb, and sill using the supplied # 8 x 1 Philips pan head screws at each assembly hole. (See Figure 3)

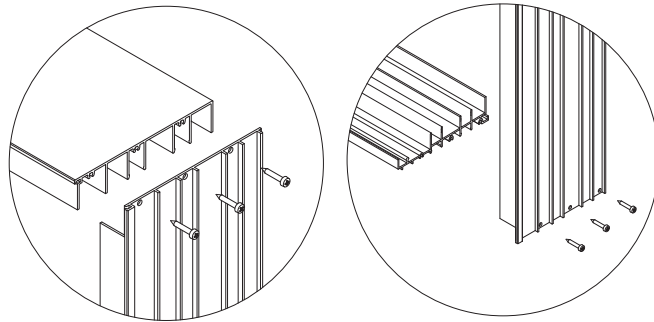
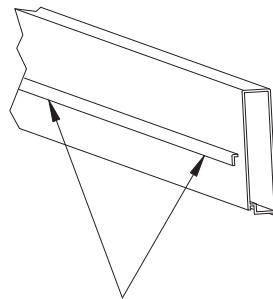

Figure 3

3. Apply the sill riser adapter to the main frame sill. First, place sealant along entire length of riser adaptor in area shown (See Figure 4)



APPLY SEALANT INSIDE GROOVE
BEFORE INSTALLING.

Figure 4

4. Set the track on an even flat, fully supported surface and then connect the sill riser to the sill. (See Figure 5)

5. Make sure the opening which the door is to be installed to is clean and clear of debris.

Note: Do not force the frame into the opening. If the frame is tight then clear away obstructions.

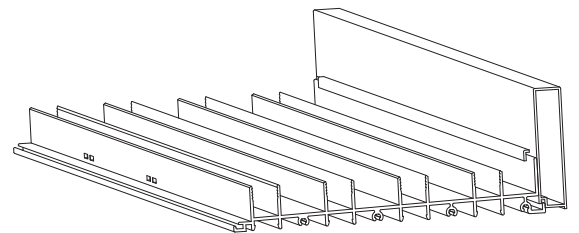

Figure 5

6. Seal under entire length of sill, where mitered corners meet, and all frame seams. Make sure to include where the frame sill and head meet the main frame jambs. (See Figure 6)

7. Set frame in opening and shim as necessary to make frame plumb, level and square. If space exists between substrate and frame, shim behind all installation screws to prevent frame distortion when installation screws are tightened.

8. When checking for plumb it is important to remember that the head and sill are different widths. Make sure you align the fins of the header with the fins of the sill.

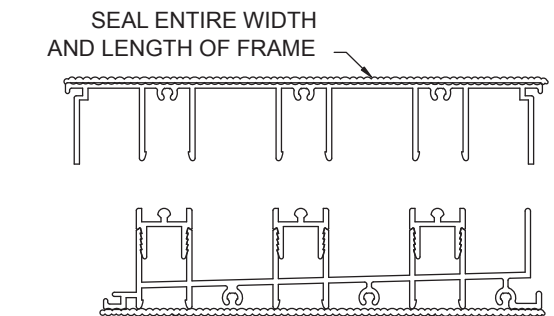

Figure 6

9. Important: Frame head and track must be level and square. Frame jamb must be plumb. Measure at head, sill and mid point horizontally to be certain that frame is not bowed, also measure from top to bottom across the entire frame from left to right to make sure there are no rises in the sill or dips in the header. Rises in the sill or dips in the header could prevent the panels from getting installed. Do not over tighten frame installation screws this could warp the frame. (See Figure 7)

10. Attach frame to opening as per PGT's specifications and in compliance with all local code requirements, Miami-Dade NOA or test reports.

11. Once the frame is secured and is plumb, level, and square, seal installation screws.

12. After installation screws are sealed, install the sill inserts. There is one insert for each track. The inserts will be different lengths due to the miter. Make sure that inserts are tight to the corner so gaps are minimal. (See Figure 8)

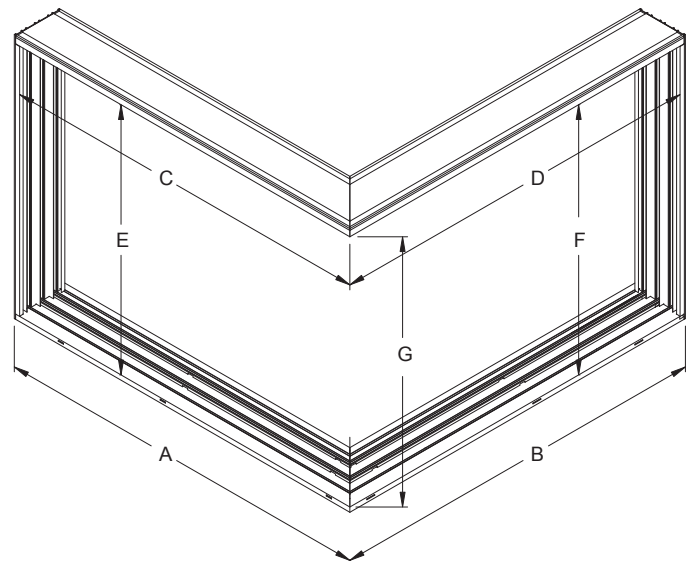

Figure 7

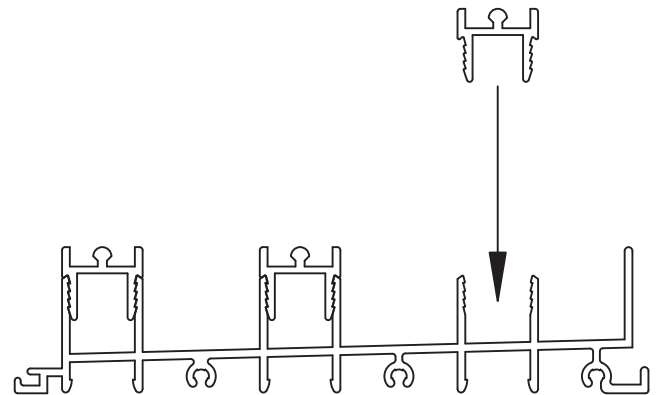

Figure 8

13. Next install the main frame head screw covers. Snap the screw cover in at corner making sure that the seam is minimal. Tap the cover into place with a plastic mallet making sure the cover is not separating from the corner. The head screw covers will fit part way into the main frame jambs. You may have to arch the material to get them in tight. (See Figure 9)

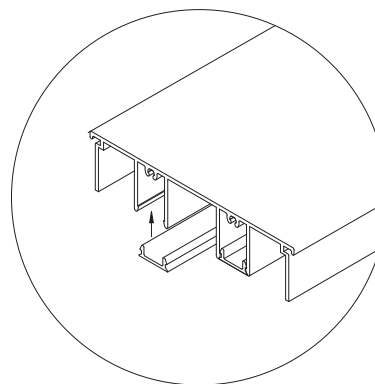

Figure 9

14. Install the main frame jamb screw covers. They will fit in-between the sill inserts and head screw covers. (See Figure 10)

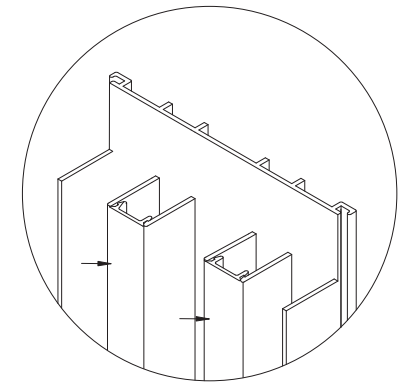

Figure 10

Note: Main frame jamb screw covers in tracks where keepers or fixed panel clips are to be installed should be installed at the end of installation. This will allow for proper placement and adjustment of keepers and clips. The main frame jamb screw covers will need to be trimmed to size once keepers have been adjusted.

SECTION 2.1: FRAME ASSEMBLY POCKET

If unit being installed has only bypass doors, skip to the next section.

1. Gather the main frame header and sill. Trace the frame head and sill ends with sealant on the mitered end. Corner pocket doors do not have a frame jamb. P-hook(s) will attach interior panels to substrate; therefore there is not any assembly of the mainframe.

2. Apply the sill riser adapter to the main frame sill. First, place sealant along entire length of riser adaptor as shown. (See Figure 11)

Important: Sill riser must be installed prior to the p-hook being installed.

3. Set the track on an even flat, fully supported surface, and then connect the sill riser to the sill. (See Figure 12)

Note: Do not force the frame into the opening. If the frame is tight then clear away obstructions.

Note: Sill riser can be attached near the end of the installation but must be attached prior to installation of the p-hook should panels need to be set from the inside or to protect from job site damage. When using the box (standard) riser allow for the additional depth the riser will add to the sill towards the inside. If this additional depth is not accounted for there may not be enough room to install the riser. It is recommended that the sill riser be attached (without sealant) until the main frame is secured.

4. Make sure the opening which the door is to be installed to is clean and clear of debris.

5. Seal under entire length of sill, where mitered corners meet, and all frame seams. Make sure to include where the frame sill and head meet the p-hook. (See Figure 13)

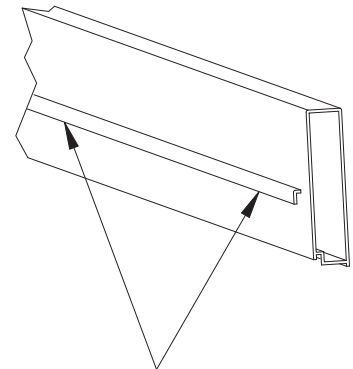

APPLY SEALANT INSIDE GROOVE BEFORE INSTALLING.

Figure 11

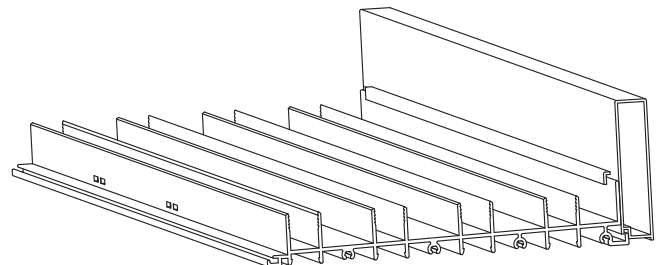

Figure 12

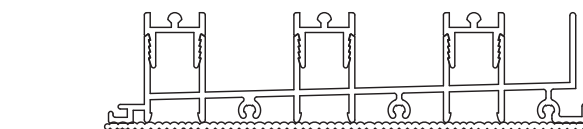
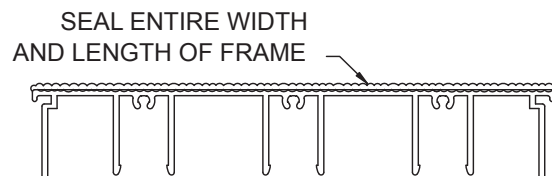

Figure 13

6. Set frame in opening and shim as necessary. Make sure frame is plumb, level and square. If space exists between substrate and frame, shim behind all frame installation screws to prevent frame distortion when installation screws are tightened.

7. When checking for plumb it is important to remember that the head and sill are different widths. Make sure you align the fins of the header with the fins of the sill.

Important: Frame head and track must be level, square and plumb. Measure at head, sill and midpoint horizontally to be certain that frame is not bowed, also measure from top to bottom across the entire frame from left to right to make sure there are no rises in the sill or dips in the header. Rises in the sill or dips in the header could prevent the panels from getting installed. Do not over tighten frame installation screws this could warp the frame.(See Figure 14)

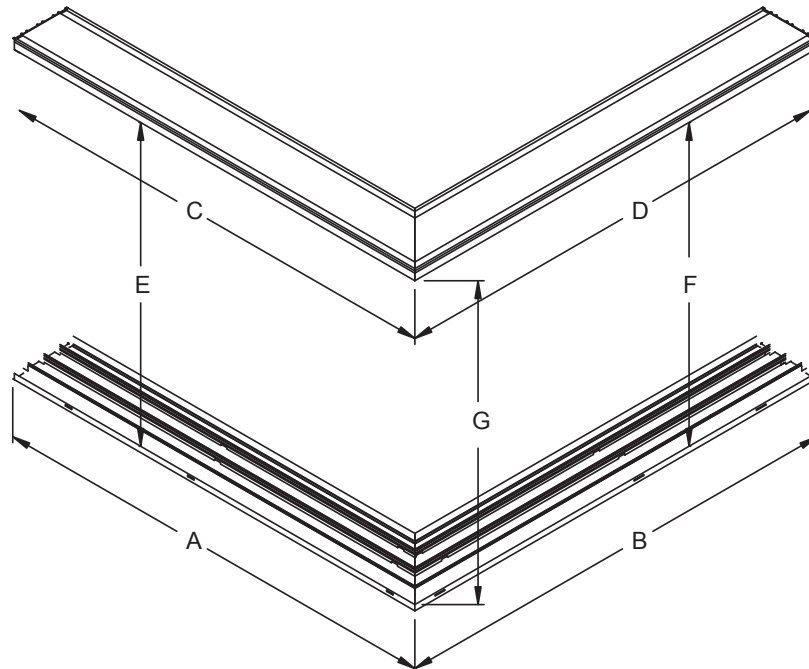

Figure 14

Helpful Tip: Use a short torpedo level across the sill (without setting it on the riser) and at the head to verify the sill and head are level from inside to outside. If the track at sill or head are not level from inside to outside it could cause stiff panel operation. Take notice that the head and sill are not the same depth, it is important to make sure that the tracks align at the head and sill in order for the panels to roll correctly. Use a plumb bob to make sure the head and sill are in alignment, this is especially important in pocket conditions.

8. Attach frame to opening as per PGT specifications and in compliance with all local code requirements, Miami-Dade NOA or test reports.

9. Next attach the P-hook.

10. The P-hook is not notched and sits on top of the sill riser and just under the header. There are two types of P-hooks, one for the narrow sill riser and one for the box (standard) riser. (See Figure 15)

11. Hook strip P-hook will attach interior panels to substrate. Attach frame and hook strip to opening as per PGT's specifications and in compliance with all local code requirements, Miami-Dade NOA or test reports.

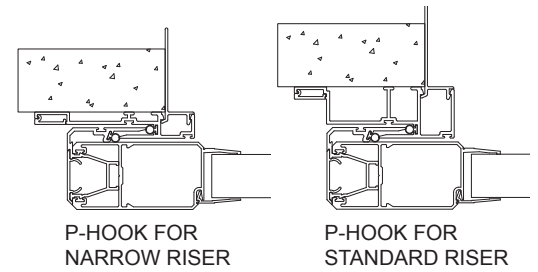

Figure 15

12. If a panel is not available to set the location of the p-hook from inside to outside then align the p-hook with the riser and header as shown. (See Figure 16)

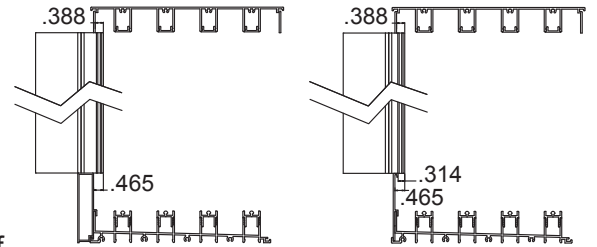

Figure 16

13. The hook strip may need to be field notched or ordered longer if jumping tracks with a build out. (See Figure 17)

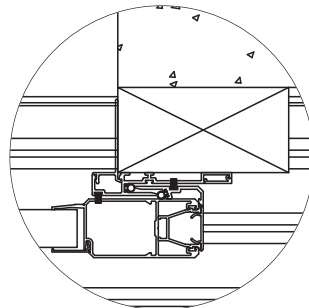

Figure 17

14. Once the frame is secured and is plumb, level, and square; seal installation screws.

15. After installation screws are sealed, install the sill inserts. There is one insert for each track. (See Figure 18)

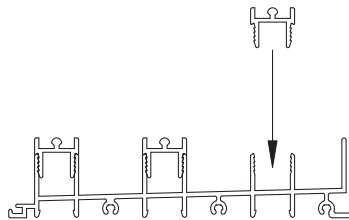

Figure 18

16. Next install the main frame head screw covers and P-hook screw covers. (See Figure 19) (See Figure 19a)

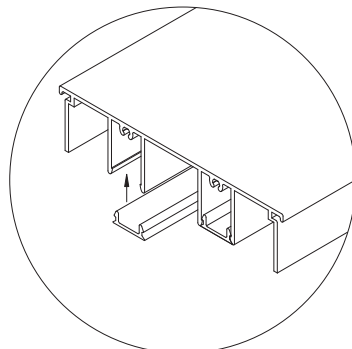

Figure 19

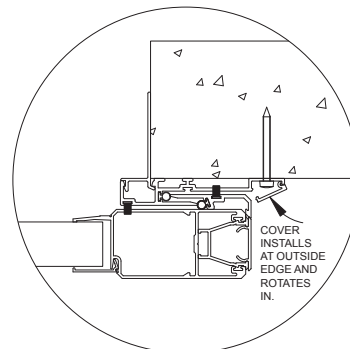

Figure 19a

SECTION 3: PANEL INSTALLATION

BEFORE YOU START please note the following: PGT offers many configurations; please see the panel orientation sheet to make sure you have the correct panels on the correct tracks.

• Shipping labels on panels will have the panel # and letter name on them; they will be installed in order from left to right. Please see the configuration page for the proper track the panel goes into. (See Figure 20)

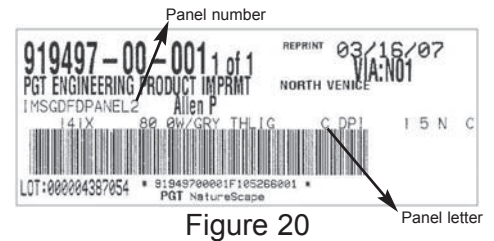

Figure 20

17. Position panel so that the top of panel slips over track frame header. Swing bottom of panel in until bottom of panel is aligned over sill and set panel on roller spline. (See Figure 21)

18. Repeat procedure, with next outer panel until all panels are installed.

19. Panels are always installed with roller adjustment holes to the exterior.

20. It is important that the panels at the corner are adjusted first. The corner receiving panel fins must align with the frame head and sill tracks. (See Figure 22)

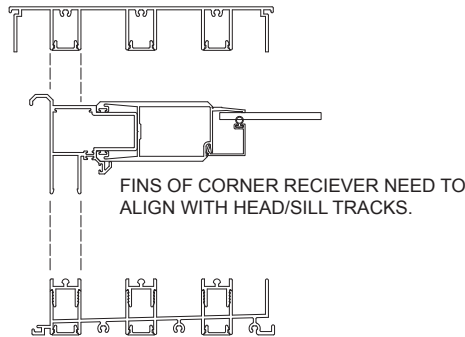

Figure 22

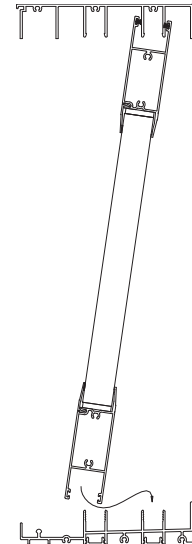

Figure 21

21. To adjust rollers on panels use a Phillips head screwdriver to turn adjustment screws located on the bottom outside of panel. (See Figure 23)

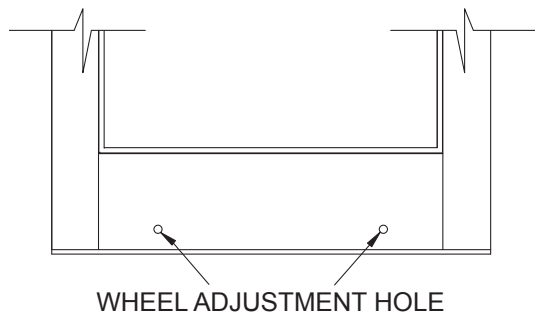

Figure 23

22. Screw guns can strip the adjustment and therefore are not recommended. To raise panels, pick up the panel at the edge to relieve the weight pressure on the wheels, and then adjust by turning adjustment screw clockwise. To lower panels turn adjustment screws counter clockwise then use weight pressure on the panel to set the wheels to the new adjustment level.

WARNING: When raising and lowering the wheels, if you feel pressure do not continue as this could cause the adjustment screw to strip. Adjust each panel until all panels roll freely and all panels' stiles and frame jambs are parallel when in the closed position.

23. Once all panels are set into place and have been adjusted properly, check the reveals and operations to verify that everything is in proper working order. You are now ready to start to install the hardware. (See Figure 24)

It is recommended to install the locking hardware BEFORE attaching any of the fixed panel hardware.

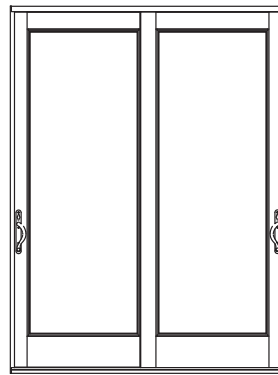

CORRECT
PANELS STILES AND FRAME
JAMBS ARE PARALLEL

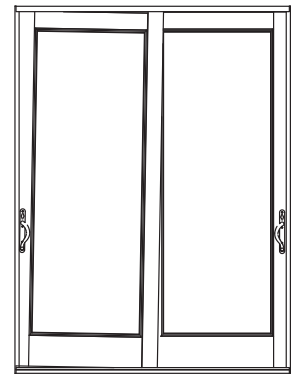

INCORRECT
PANELS STILES AND FRAME
JAMBS ARE SKEWED

Figure 24

SECTION 4: LOCKING HARDWARE

Door to Jamb Connection (See Figure 25)

24. Align the thumb turn tail piece of the interior handle into the slot of the mortise assembly.

25. Attach handles using the three (2) #8-32 pan head screws provided.

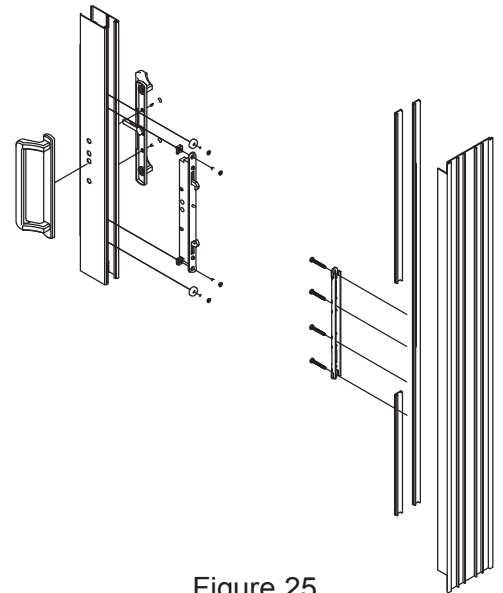

Figure 25

SECTION 5: KEEPER INSTALLATION

26. Attach keeper to frame jamb using four (4) #10 X 1 1/2" pan head screws. Track will be dimpled in the location the keeper is installed into the frame jamb.

27. With the mortise lock latch extended, adjust the keeper to maximize bite with the latch. Check operation of the lock and adjust the keeper up or down if required.

HELPFUL TIP: There is adjustment on the latch to move the cams in or out. Adjust the cams independently to remove play or add play to the latch engagement in the panel. If your unit has fixed panels it is recommended to adjust the cams in tight until the fixed panel is secured. Once the fixed panel(s), fixed panel clip(s), and retainer clip(s), have been completely installed readjust cams to allow for a little bit of play in the operating door(s) (See Figure 26)

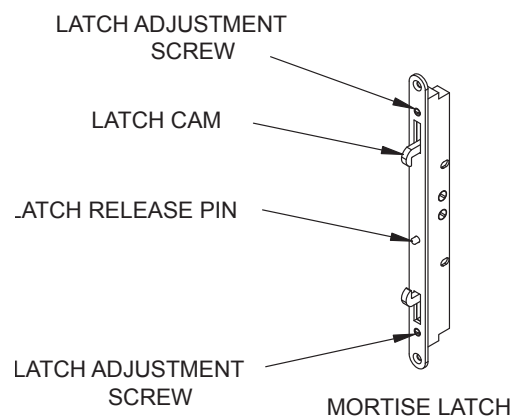

Figure 26

SECTION 6: LOCKING HARDWARE

Door to Door Connection at corner (See Figure 27)

1. Align the lever tail piece of the interior handle into the slot of the mortise assembly.

2. Attach handles using the two (2) #8-32 pan head screws provided.

Note: latch may not be operated unless the safety pin (located between the two mortise cams) is depressed.

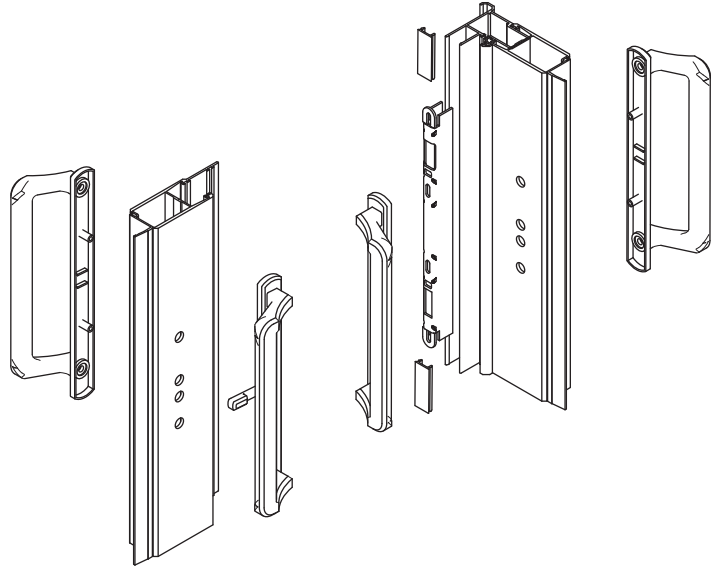

Figure 27

SECTION 7: KEEPER INSTALLATION

1. Attach keeper to corner receiver panel astragal using four (4) #10 X 1 1/2" pan head screws. Corner receiving astragal will be dimpled in the location the keeper is installed into the frame jamb.

2. With the mortise lock latch extended, adjust the keeper to maximize bite with the latch. Check operation of the lock and adjust the keeper up or down if required.

HELPFUL TIP: There is adjustment on the latch to move the cams in or out. Adjust the cams independently to remove play or add play to the latch engagement in the panel. If your unit has fixed panels it is recommended to adjust the cams in tight until the fixed panel is secured. Once the fixed panel(s), fixed panel clip(s), and retainer clip(s), have been completely installed, readjust cams to allow for a little bit of play in the operating door(s) (See Figure 28)

3. If the door has the recessed hardware or any secondary lock hardware, follow the same procedures listed above.

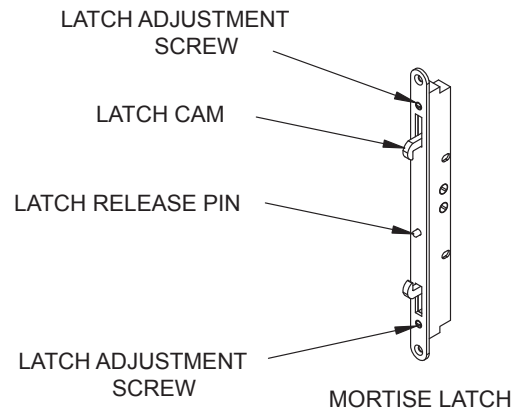

Figure 28

SECTION 8: FIXED PANEL HARDWARE

If there are any non-moving panels in your configuration then proceed to fixed panel hardware section. If not, skip to the Parts and Pieces Section.

4. Each fixed panel has one 6" fixed panel clip and one retaining clip.

5. The fixed panel clip will snap into the main frame jamb at the center of the height of the jamb. Attach the clip to the Main frame jamb by tapping it into place with a hard plastic mallet.

Note: Be sure the “Fins” on the clip are facing the interior of the house. (See Figure 29)

6. Once the clip is snapped firmly into place on the frame jamb and the fins are positioned to the inside of the house, lock the operating panels with the cams adjusted all the way in, close the fixed panels over the clips.

7. The fins from the clip will make interference with the stile and lock the panel into place.

8. Once the fixed panels are locked into place, install the retaining clip. The clip is installed on the interior of the home as well and will fit between the stile of the door and the main frame jamb leg.

Note: the retaining clip must be installed so that the panel cannot be pushed on from the exterior and disengaged from the fixed panel clip. There are 2 different retaining clips., one for fixed panels that are on the inner most track of the home (Track 1) and one for fixed panel that are on all other tracks. Be sure to reference the test report or Miami-Dade NOA for proper quantity and placement of the fixed panel clips.

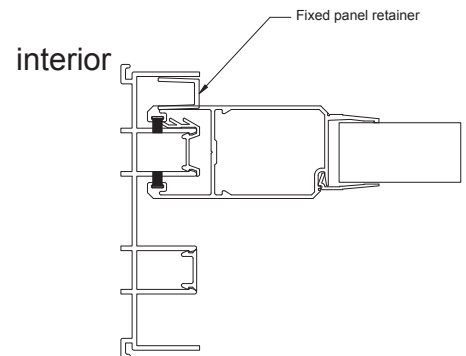
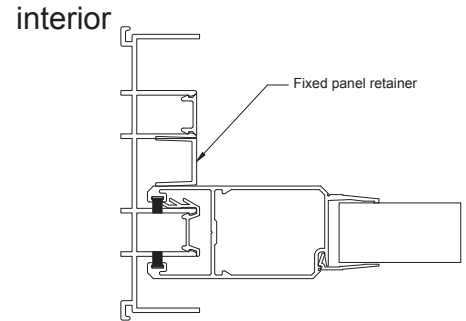

Figure 29

Parts and Pieces

After the above steps have been completed, the unit is operating properly, and is set in place you are ready for the final parts and pieces, such as:

High Pile Dust Plugs:

Dust plugs are used to fill any voids where interlocking panels are set in the closed position and require a weather seal. Position two high pile pads above and below the interlocking section of the doors in the closed position. To do this, mark the area where the doors interlock together in the closed position. Then open the panels and place the high pile pads on the extrusion making sure that the adhesive backing makes good contact to the extrusion. (See Figure 30)

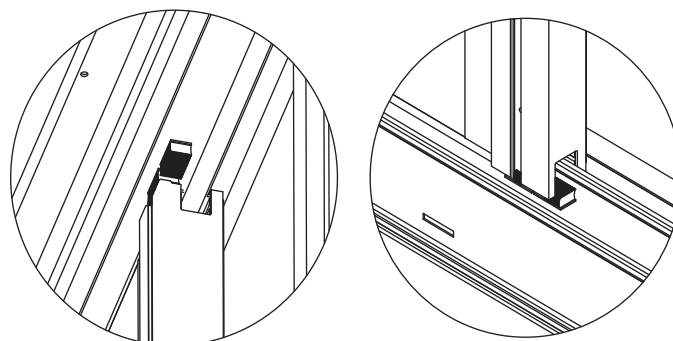

Figure 30

Note: Riser heights will determine how many dust plugs will be needed at the sill. Install as many as needed to fill the void from the bottom of the panel to the underside of the P-hook. (See Figure 31)

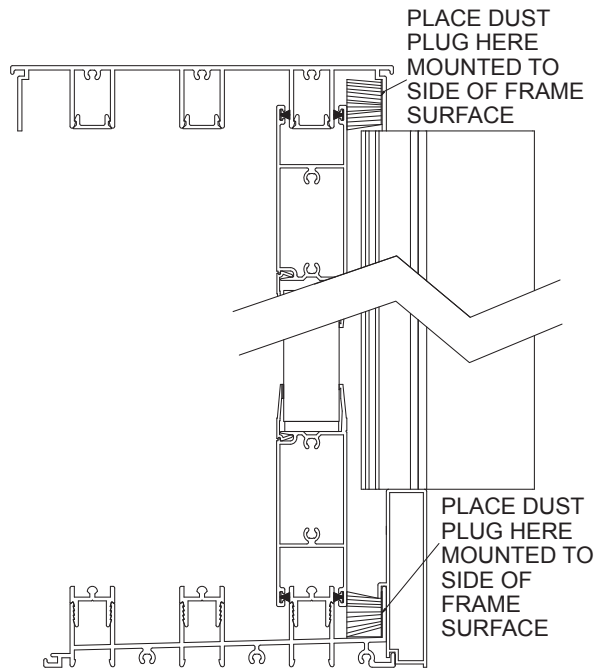

Figure 31

Note: It may be necessary to clean the surface that you are applying the adhesive high pile dust pads to if they have debris or cutting oils on them. Apply the pads to a dry clean surface.

Note: On some configurations you may have to mark the track and then remove the panels to get the pads into place.

SECTION 9: PANEL BUMPERS

The 4 hole bumper stop can be used to stop the travel of a panel on a by-pass or to keep a panel from rolling off the track when installing a pocket door. For a by-pass it should be placed on the sill in such a way to keep the locking handle from making contact with the next doors interlock. On a pocket door unit it should be installed to keep a panel from rolling off of the end of a track. (See Figure 32)

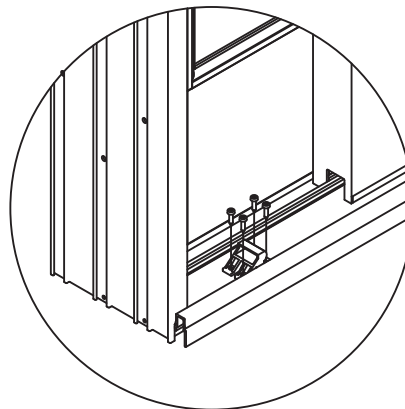

Figure 32

Note: For multiple panel units it may be necessary to also use the panel come-a-long in conjunction with the 4 hole bumper stops.

Panel Come-A-Long:

If the unit is a multi-panel, multi-tracked, or pocket door unit you may install panel come-a-longs. This will allow the door to open without having to move each panel individually and also keep the panels from hitting the interlocks or making contact with the handle hardware. They may be installed at the top of the door panel. (See Figure 33)

The come-a-long should be located in front of the vertical stile at the top rail. As the panel moves down the track it will make contact with the panel come-a-long and start driving the next panel down the track. It installs with two # 8" x 1 1/4" sheet metal screws. When located in the correct position it should leave a gap between the handle and the interlock of the panel.

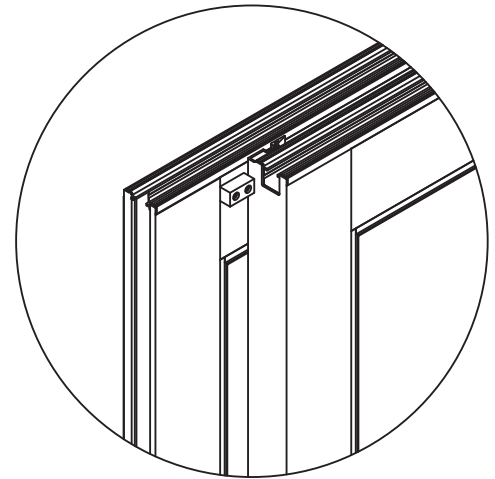

Figure 33

Note: Installing come-a-longs in the bottom rail of the panel could prohibit the roller from operating correctly as the screw could bind into the roller housing.

Note: Do not locate the part in any other area than shown in the drawing; doing so could cause damage to the frame or glass. Do not use longer screws. Doing so could cause interference or operational problems.

Adjustment Hole Plug:

Once the doors are installed and working properly, install the roller adjustment hole plugs. There are two per operable panel and should be located on the outside face of the door. (See Figure 34)

Final Screw Covers:

Once the installation is complete, install any remaining screw covers. This includes screw covers that need to be cut to size that fit above and below the frame jamb keepers or corner astragal keepers. If the unit is a pocket door, there will also be a screw cover to conceal the screws on the P-hook. (See Figure 34a)

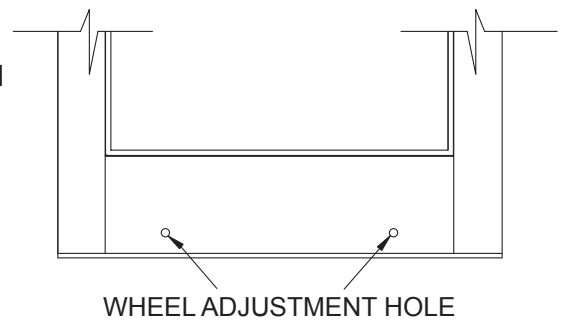

Figure 34

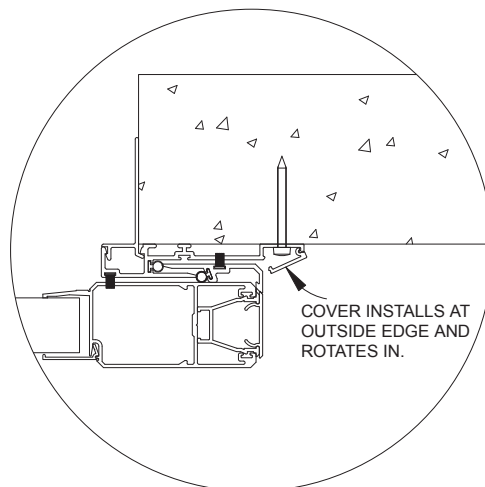

Figure 34a

OUTSIDE CORNER LEFT SIDE CONFIGURATIONS

TYPE	PRIMARY	SECONDARY
2P2T XX		
3P3T XXX		
4P4T XXXX		
2P2T OX		
3P3T OXX		
4P4T OXXX		

OUTSIDE CORNER RIGHT SIDE CONFIGURATIONS

TYPE	PRIMARY	SECONDARY
2P2T XX		
3P3T XXX		
4P4T XXXX		
2P2T XO		
3P3T XXO		
4P4T XXXO		

OUTSIDE CORNER POCKET CONFIGURATIONS

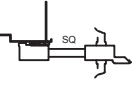
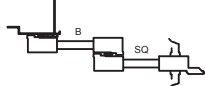
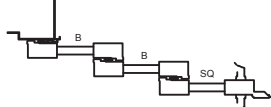
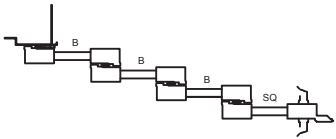
TYPE	PRIMARY LEFT HAND POCKETS
1P2T 1 POCKET	
2P2T 1 POCKET	
3P3T 1 POCKET	
4P4T 1 POCKET	

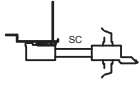
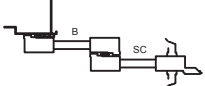
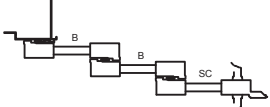
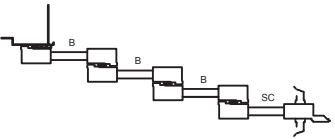
TYPE	SECONDARY LEFT HAND POCKETS
1P2T 1 POCKET	
2P2T 1 POCKET	
3P3T 1 POCKET	
4P4T 1 POCKET	

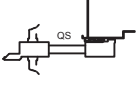
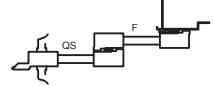
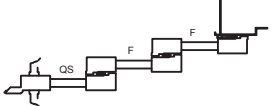
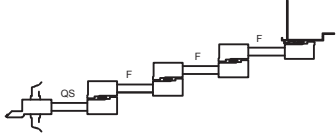

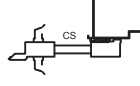
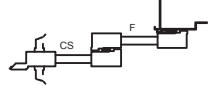
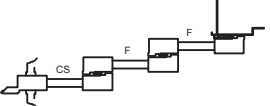
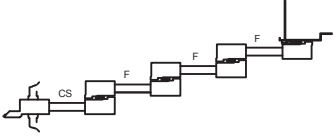

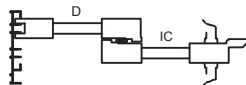
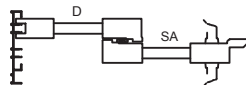
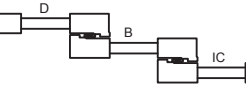
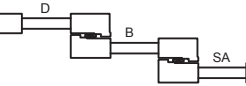
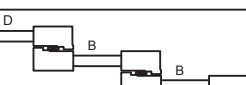
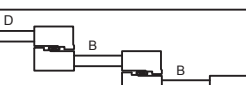
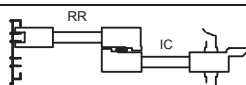
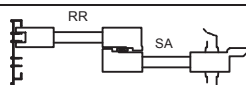
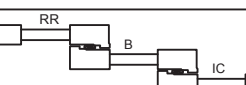
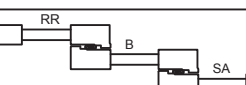
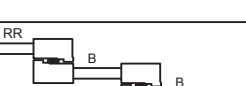
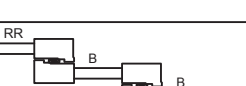

TYPE	PRIMARY RIGHT HAND POCKETS
1P2T 1 POCKET	
2P2T 1 POCKET	
3P3T 1 POCKET	
4P4T 1 POCKET	

TYPE	SECONDARY RIGHT HAND POCKETS
1P2T 1 POCKET	
2P2T 1 POCKET	
3P3T 1 POCKET	
4P4T 1 POCKET	

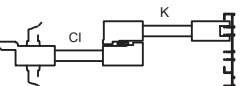
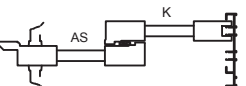
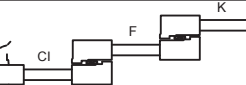
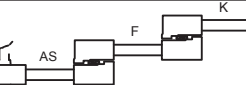
INSIDE CORNER LEFT SIDE CONFIGURATIONS

TYPE	PRIMARY	SECONDARY
2P2T XX		
3P3T XXX		
4P4T XXXX		
2P2T OX		
3P3T OXX		
4P4T OXXX		

INSIDE CORNER RIGHT SIDE CONFIGURATIONS

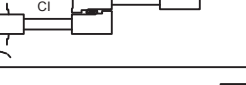
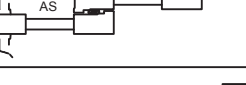
TYPE	PRIMARY	SECONDARY
2P2T XX		
3P3T XXX		
4P4T XXXX		
2P2T XO		
3P3T XXO		
4P4T XXXO		

INSIDE CORNER POCKET CONFIGURATIONS

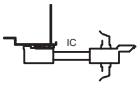
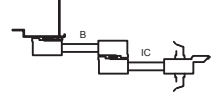
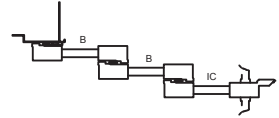
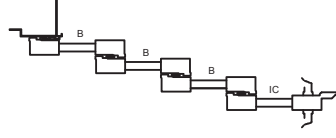

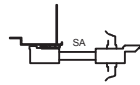
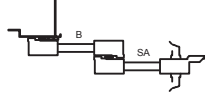
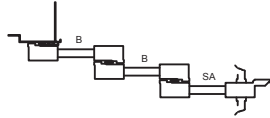
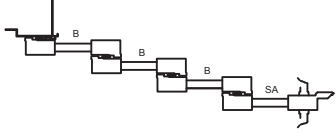

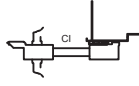
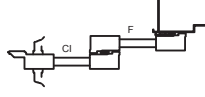
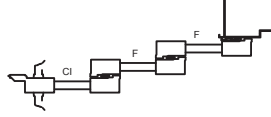
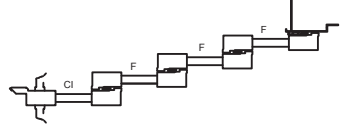

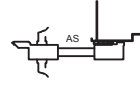
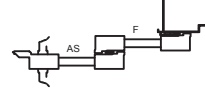
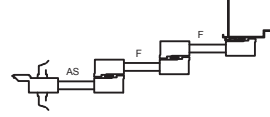
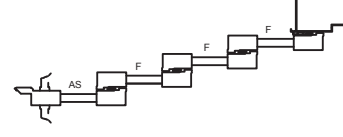





























TYPE	PRIMARY LEFT HAND POCKETS
1P2T 1 POCKET	
2P2T 1 POCKET	
3P3T 1 POCKET	
4P4T 1 POCKET	

TYPE	SECONDARY LEFT HAND POCKETS
1P2T 1 POCKET	
2P2T 1 POCKET	
3P3T 1 POCKET	
4P4T 1 POCKET	

TYPE	PRIMARY RIGHT HAND POCKETS
1P2T 1 POCKET	
2P2T 1 POCKET	
3P3T 1 POCKET	
4P4T 1 POCKET	

TYPE	SECONDARY RIGHT HAND POCKETS
1P2T 1 POCKET	
2P2T 1 POCKET	
3P3T 1 POCKET	
4P4T 1 POCKET	

CORNER - PANEL TYPES

PANEL LETTER				
CS	CORNER RECEIVER			SINGLE INTERLOCK
SC	SINGLE INTERLOCK			CORNER RECEIVER
QS	CORNER LOCKSTILE			SINGLE INTERLOCK
SQ	SINGLE INTERLOCK			CORNER LOCKSTILE
AS	CORNER RECEIVER			SINGLE INTERLOCK
SA	SINGLE INTERLOCK			CORNER RECEIVER
CI	CORNER LOCKSTILE			SINGLE INTERLOCK
IC	SINGLE INTERLOCK			CORNER LOCKSTILE
CF	CORNER RECEIVER			FIXED LOCKSTILE
FC	FIXED LOCKSTILE			CORNER RECEIVER
A	SINGLE INTERLOCK			LOCKSTILE
D	LOCKSTILE			SINGLE INTERLOCK
M	LOCKSTILE			SINGLE INTERLOCK
B	SINGLE INTERLOCK			SINGLE INTERLOCK
F	SINGLE INTERLOCK			SINGLE INTERLOCK
K	SINGLE INTERLOCK			LOCKSTILE
RR	FIXED LOCKSTILE			SINGLE INTERLOCK
PP	SINGLE INTERLOCK			FIXED LOCKSTILE



CUSTOM WINDOWS + DOORS



PGTINDUSTRIES.COM | N. VENICE, FL
©2018 PGT CUSTOM WINDOWS + DOORS
03/2018 MB0200361