

**GENERAL NOTES: SERIES 5520
IMPACT RESISTANT, VINYL FIXED WINDOW**

1) THIS PRODUCT HAS BEEN DESIGNED & TESTED TO COMPLY WITH THE REQUIREMENTS OF THE FLORIDA BUILDING CODE.

2) ALL WOOD BUCKS LESS THAN 1-1/2" THICK ARE TO BE CONSIDERED 1X INSTALLATIONS. 1X WOOD BUCKS ARE OPTIONAL IF UNIT IS INSTALLED DIRECTLY TO SUBSTRATE. WOOD BUCKS DEPICTED AS 2X ARE 1-1/2" THICK OR GREATER. 1X AND 2X BUCKS (WHEN USED) SHALL BE DESIGNED TO PROPERLY TRANSFER LOADS TO THE STRUCTURE. WOOD BUCK DESIGN AND INSTALLATION IS THE RESPONSIBILITY OF THE ENGINEER, (EOR) OR ARCHITECT OF RECORD, (AOR).

3) ANCHOR EMBEDMENT TO BASE MATERIAL SHALL BE BEYOND WALL DRESSING OR STUCCO. USE ANCHORS OF SUFFICIENT EMBEDMENT. INSTALLATION ANCHORS SHOULD BE SEALED. OVERALL SEALING/FLASHING STRATEGY FOR WATER RESISTANCE OF INSTALLATION SHALL BE DONE BY OTHERS AND IS BEYOND THE SCOPE OF THESE INSTRUCTIONS.

4) MAX. 1/4" SHIMS ARE REQUIRED AT EACH ANCHOR LOCATION WHERE THE PRODUCT IS NOT FLUSH TO THE SUBSTRATE. USE SHIMS CAPABLE OF TRANSFERRING APPLIED LOADS. WOOD BUCKS, BY OTHERS, MUST BE SUFFICIENTLY ANCHORED TO RESIST LOADS IMPOSED ON THEM BY THE WINDOW.

5) THE ANCHORAGE METHODS SHOWN HAVE BEEN DESIGNED TO RESIST THE WINDLOADS CORRESPONDING TO THE REQUIRED DESIGN PRESSURE. THE 33-1/3% STRESS INCREASE HAS NOT BEEN USED IN THE DESIGN OF THIS PRODUCT. THE 1.6 LOAD DURATION FACTOR WAS USED FOR THE EVALUATION OF ANCHORS INTO WOOD. ANCHORS THAT COME INTO CONTACT WITH OTHER DISSIMILAR MATERIALS SHALL MEET THE REQUIREMENTS OF THE FLORIDA BUILDING CODE FOR CORROSION RESISTANCE.

IMPACT RATING	DESIGN PRESSURE RATING
LARGE & SMALL MISSILE IMPACT RESISTANT	SEE TABLE 1

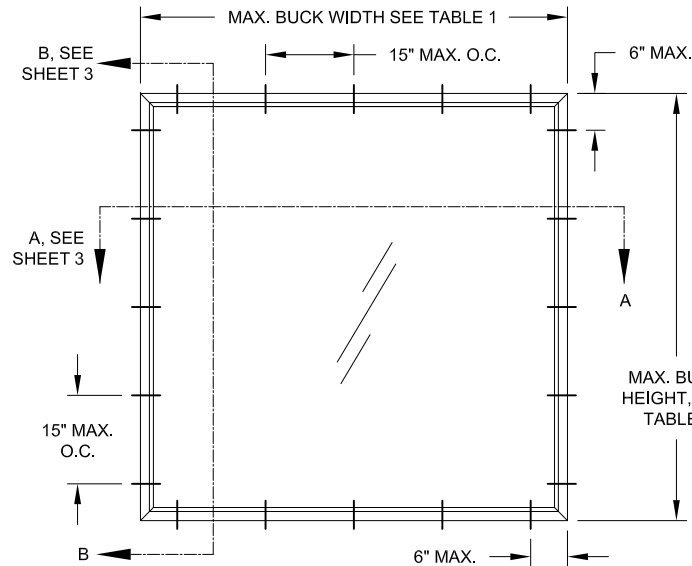

**TYP. EQUAL-LEG/BOX & FLANGE
FRAME (SHAPES SIMILAR)**

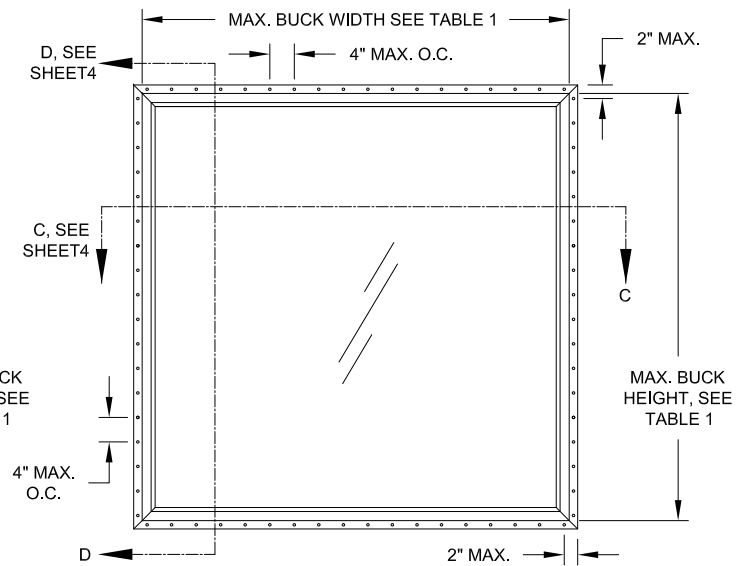

**TYP. INTEGRAL FIN & J-CANNEL
FRAME (SHAPES SIMILAR)**

SHAPES MAY BE USED BY INSCRIBING THE SHAPE IN A BLOCK AND OBTAINING DESIGN PRESSURES FOR THAT BLOCK SIZE FROM THE TABLE ON THIS SHEET.

TABLE 1:

Window Buck Size		Design Pressure		Certification (CAR) Number
Width	Height	(+) psf	(-) psf	
84	54	65.0	65.0	190-281, 1019
84	54	70.0	70.0	190-284, 1019
84	72	70.0	70.0	190-279, 1012
96	63	70.0	70.0	190-283, 1020
75	48	50.0	50.0	190-280, 1013
36	72	50.0	50.0	190-282, 1014

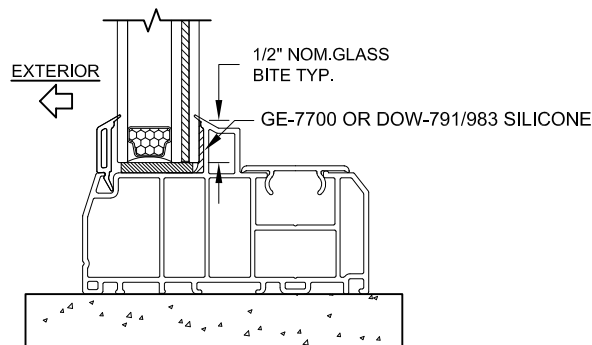

TYP. GLAZING DETAIL

COPYRIGHT © 2021
PGT INDUSTRIES, INC.
LIMITED LICENSE TO MAKE
COPIES FOR PERMITTING.
CERT. OF AUTH. #29296
1070 TECHNOLOGY DRIVE
N. VENICE, FL 34275 (941)-480-1600

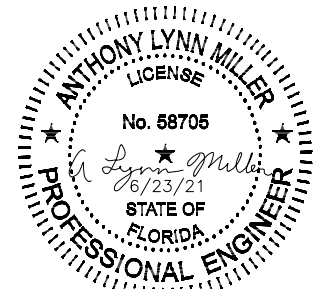

A. LYNN MILLER, P.E.
P.E.# 58705

Rev. Desc.	MINOR EDITS	Sheet	By	JR	Date	06/16/21
------------	-------------	-------	----	----	------	----------

Series Desc. Title	VINYL PICTURE WINDOW INSTALLATION, LM	Date	09/30/11
--------------------	---------------------------------------	------	----------

General Notes & Elevations	Drawn By	J ROSOWSKI
----------------------------	----------	------------

Series	PW5520	Sheet	1 OF 4	DWG No.	PW5520-FPA	Rev.	B
--------	--------	-------	--------	---------	------------	------	---



TABLE 2: ANCHORS INSTALLED THROUGH FRAME

Anchor	Substrate	Min. Edge Distance	Min. Embedment
#10 SMS (steel, 18-8 S.S. or 410 S.S.) Max. DP of 50.0 psf	P.T. Southern Pine (SG=0.55)	7/16"	1-3/8"
	Steel, A36	3/8"	0.050"
	Steel Stud, A653 Gr. 33	3/8"	0.0346" (20 Ga.)
	Aluminum, 6063-T5	3/8"	0.0713" (14 Ga.)
#12 SMS (steel, 18-8 S.S. or 410 S.S.)	P.T. Southern Pine (SG=0.55)	9/16"	1-3/8"
	Steel, A36	3/8"	0.050"
	Steel Stud, A653 Gr. 33	3/8"	0.0346" (20 Ga.)
	Aluminum, 6063-T5	3/8"	0.0713" (14 Ga.)
3/16" Ultracon Max. DP of 50.0 psf	P.T. Southern Pine (SG=0.55)	7/16"	1-3/8"
	Concrete (min. 2.85 ksi)	1"	1-3/8"
	UngROUTED CMU, (ASTM C-90)	2-1/2"	1-1/4"
3/16" Ultracon+ Max. DP of 50.0 psf	P.T. Southern Pine (SG=0.55)	7/16"	1-3/8"
	Concrete (min. 3 ksi)	1"	1-3/8"
	UngROUTED CMU, (ASTM C-90)	1"	1-1/4"
1/4" Ultracon	P.T. Southern Pine (SG=0.55)	1"	1-3/8"
	Concrete (min. 2.85 ksi)	1"	1-3/4"
	UngROUTED CMU, (ASTM C-90)	2-1/2"	1-1/4"
1/4" Ultracon+	P.T. Southern Pine (SG=0.55)	1"	1-3/8"
	Concrete (min. 3 ksi)	1-3/16"	1-3/4"
	UngROUTED CMU, (ASTM C-90)	1"	1-1/4"
1/4" Crete-Flex (410 S.S.)	P.T. Southern Pine (SG=0.55)	1"	1-3/8"
	Concrete (min. 3.35 ksi)	1"	1-3/4"
	UngROUTED CMU, (ASTM C-90)	2-1/2"	1-1/4"
1/4" Aggre-Gator (18-8 S.S.)	Concrete (min. 3.275 ksi)	1-1/2"	1-3/8"
	P.T. Southern Pine (SG=0.55)	1"	1-3/8"
	UngROUTED CMU, (ASTM C-90)	2"	1-1/4"

TABLE 3: ANCHORS INSTALLED THROUGH INTEGRAL FIN

Anchor	Substrate	Min. Edge Distance	Min. Embedment	
2-1/2" x .131" Common Nail Max. DP of 50.0	P.T. Southern Pine (SG=.55)	9/16"	2-7/16"	
	2-1/2" x .131" Ring-shank Nail	P.T. Southern Pine (SG=.55)	9/16"	2-7/16"
	2-1/2" x .145" Roofing Nail	P.T. Southern Pine (SG=.55)	9/16"	2-7/16"
		P.T. Southern Pine (SG=.55)	3/4"	1-3/8"
#10 SMS (steel, 18-8 S.S. or 410 S.S.)	Aluminum, 6063-T5	3/8"	0.050"	
	Steel Stud, Gr. 33	3/8"	0.0346" (20 Ga.)	
	Steel, A36	3/8"	0.050"	

ANCHOR NOTES:

- 1) "UNGROUTED CMU" VALUES MAY BE USED FOR GROUDED CMU APPLICATIONS.
- 2) PANHEAD, FLATHEAD OR HEXHEAD ARE ACCEPTABLE.
- 3) ANCHOR LENGTH TO BE SO THAT A MIN. OF 3 THREADS EXTEND BEYOND THE METAL SUBSTRATE.

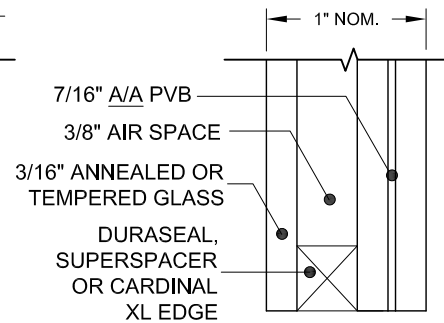
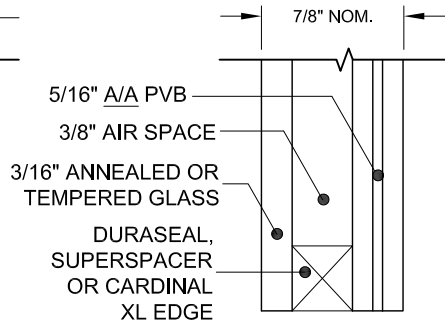
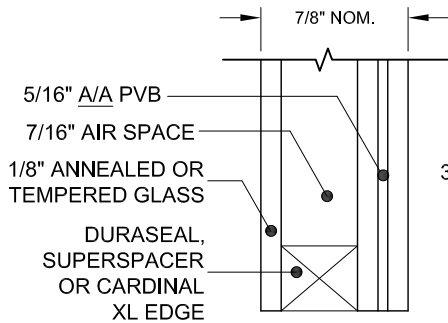
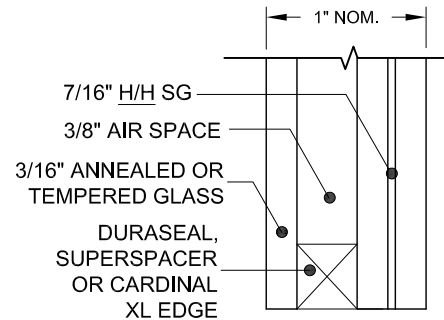

GLAZING TYPES

VISIBLE LIGHT FORMULAS

WIDTH: BUCK WIDTH - 4-5/16"
HEIGHT: BUCK HEIGHT - 4-5/16"

VISIBLE LIGHT WIDTH OR HEIGHT (ALSO REFERRED TO AS DAYLIGHT OPENING) IS MEASURED FROM BEADING TO BEADING.

PVB AND SG INTERLAYERS MANUFACTURED BY KURARAY AMERICA, INC.

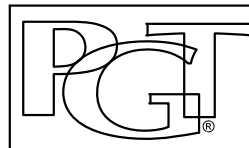

Series	Desc.	Title	Date
PW5520	Sheet	2 OF 4	DWG No.
VINYL PICTURE WINDOW INSTALLATION, LM		Date	09/30/11
GLASS/ANCHORS/FRAME OPTIONS		Drawn By	J ROSOWSKI
PW5520	Sheet	2 OF 4	DWG No.
PW5520-FPA	Rev.	B	

COPYRIGHT © 2021
PGT INDUSTRIES, INC.
LIMITED LICENSE TO MAKE
COPIES FOR PERMITTING.
CERT. OF AUTH. #29296
1070 TECHNOLOGY DRIVE
N. VENICE, FL 34275 (941)-480-1600

ANTHONY LYNN MILLER
LICENSE
No. 58705
Lynn Miller
6/23/21
STATE OF FLORIDA
PROFESSIONAL ENGINEER
A. LYNN MILLER, P.E.
P.E.# 58705

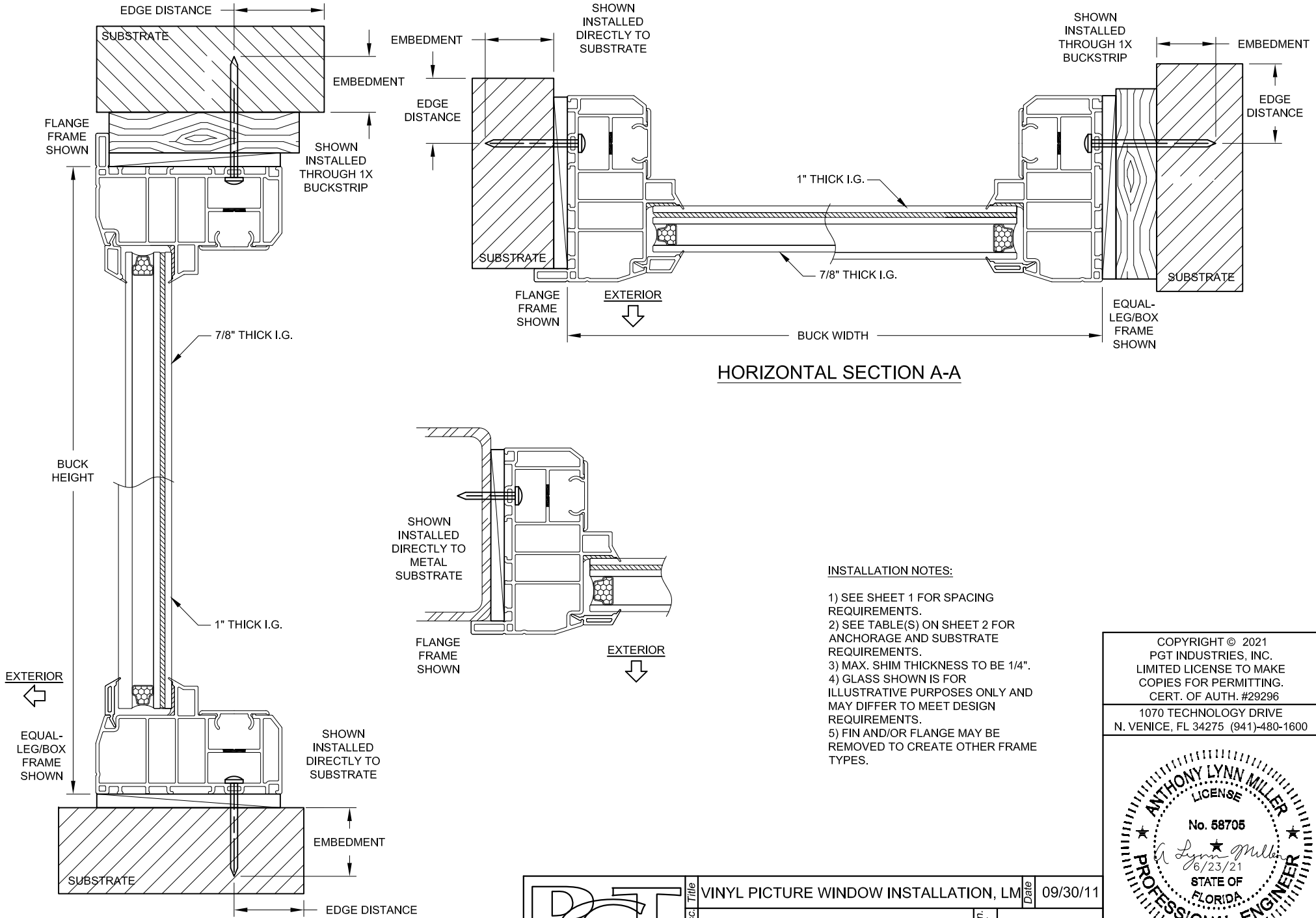

HORIZONTAL SECTION A-A

VERTICAL SECTION B-B

INSTALLATION NOTES:

- 1) SEE SHEET 1 FOR SPACING REQUIREMENTS.
- 2) SEE TABLE(S) ON SHEET 2 FOR ANCHORAGE AND SUBSTRATE REQUIREMENTS.
- 3) MAX. SHIM THICKNESS TO BE 1/4".
- 4) GLASS SHOWN IS FOR ILLUSTRATIVE PURPOSES ONLY AND MAY DIFFER TO MEET DESIGN REQUIREMENTS.
- 5) FIN AND/OR FLANGE MAY BE REMOVED TO CREATE OTHER FRAME TYPES.

COPYRIGHT © 2021
 PGT INDUSTRIES, INC.
 LIMITED LICENSE TO MAKE
 COPIES FOR PERMITTING.
 CERT. OF AUTH. #29296
 1070 TECHNOLOGY DRIVE
 N. VENICE, FL 34275 (941)-480-1600

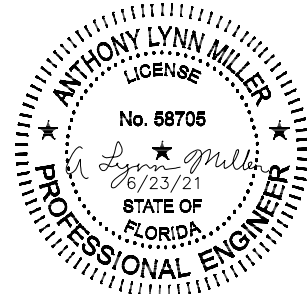

A. LYNN MILLER, P.E.
 P.E.# 58705



Series Desc. Title	VINYL PICTURE WINDOW INSTALLATION, LM		Date	09/30/11
	FLANGE/EQUAL-LEG INSTALLATION		Drawn By	J ROSOWSKI
PW5520	Sheet	3 OF 4	DWG No.	PW5520-FPA
			Rev.	B

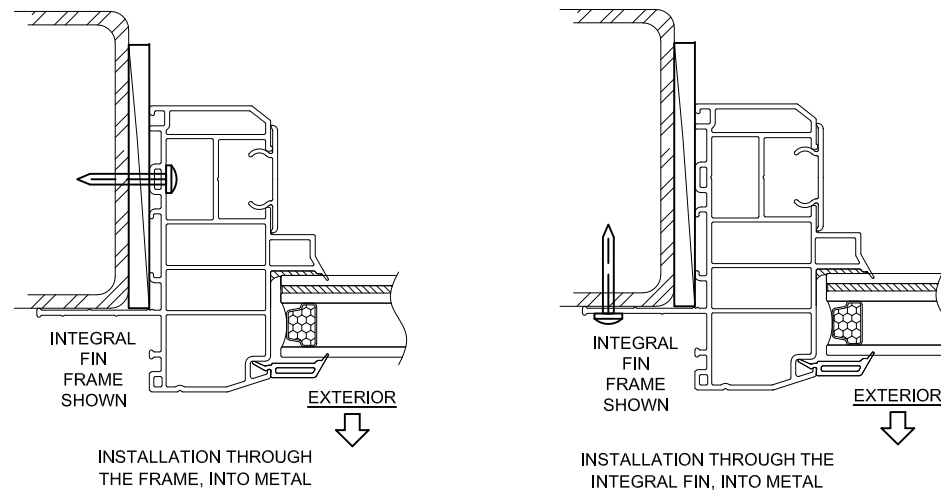
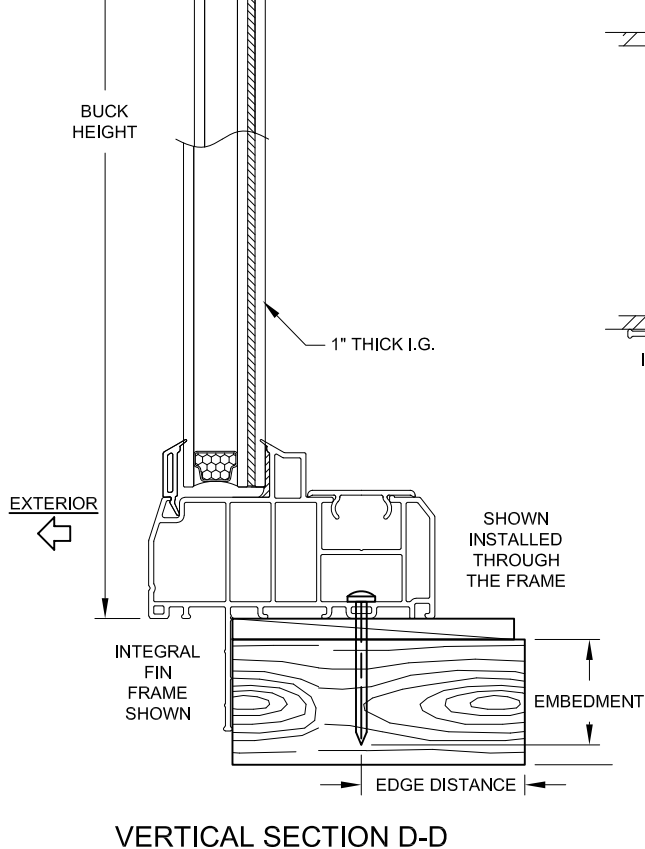
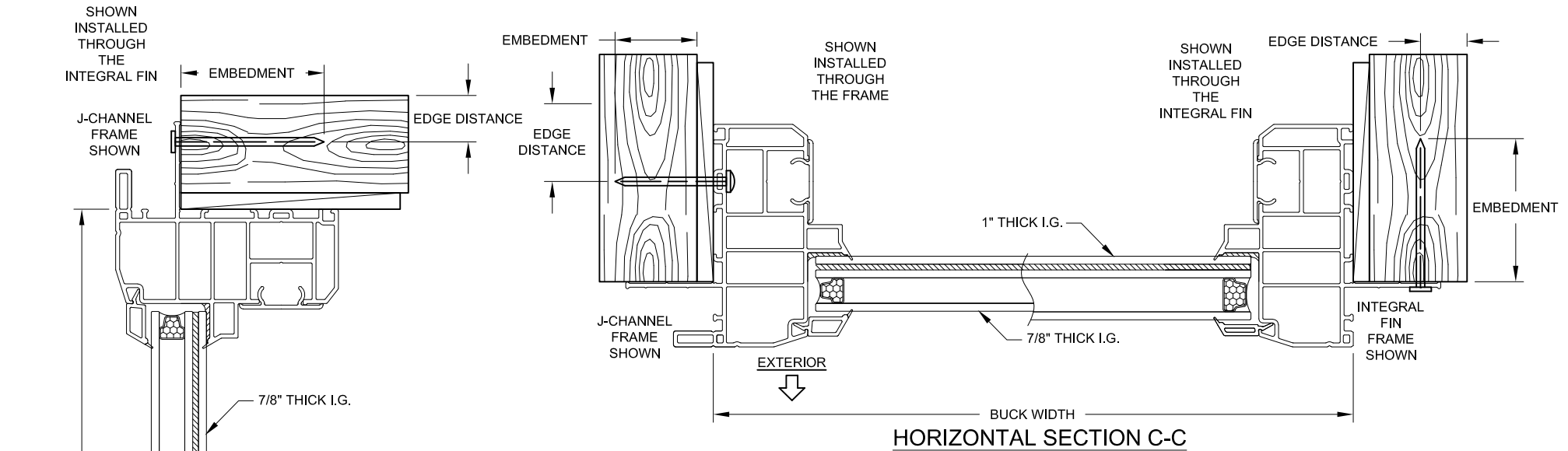

INSTALLATION NOTES:

- 1) SEE SHEET 1 FOR SPACING REQUIREMENTS.
- 2) SEE TABLE(S) ON SHEET 2 FOR ANCHORAGE AND SUBSTRATE REQUIREMENTS.
- 3) MAX. SHIM THICKNESS TO BE 1/4".
- 4) GLASS SHOWN IS FOR ILLUSTRATIVE PURPOSES ONLY AND MAY DIFFER TO MEET DESIGN REQUIREMENTS.
- 5) FIN AND/OR FLANGE MAY BE REMOVED TO CREATE OTHER FRAME TYPES.

COPYRIGHT © 2021
 PGT INDUSTRIES, INC.
 LIMITED LICENSE TO MAKE
 COPIES FOR PERMITTING.
 CERT. OF AUTH. #29296
 1070 TECHNOLOGY DRIVE
 N. VENICE, FL 34275 (941)-480-1600

ANTHONY LYNN MILLER
 LICENSE
 No. 58705
 Lynn Miller
 6/23/21
 STATE OF
 FLORIDA
 PROFESSIONAL ENGINEER

A. LYNN MILLER, P.E.
 P.E.# 58705

PGT	Series	VINYL PICTURE WINDOW INSTALLATION, LM		Date	09/30/11
	Desc.	INTEGRAL FIN INSTALLATION		Drawn By	J ROSOWSKI
	PW5520	Sheet	4 OF 4	DWG No.	PW5520-FPA
				Rev.	B