

# Sliding Glass Door Assembly Instructions













SERIES 680/780





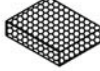
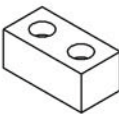

**CUSTOM WINDOWS + DOORS**

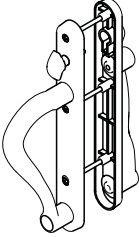
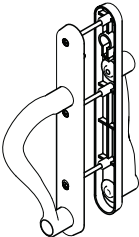

# 680/780 Parts List

PARTS					
DESCRIPTION		PARTS BAG QTY.	DESCRIPTION		
	FRAME ASS'Y SCREW #8 x 1" LONG	16 per bag		HEAVY DUTY 4 HOLE BUMPER STOP	2 per operable panel
	Screw used to assembly the main frame.			Reinforced vinyl stop attaches to header & sill of the mainframe. Used to prevent the "X" panel from impacting components adjacent to it. Also prevents pocket panels from rolling off the track.	
	"O" PANEL CLIP & BOX SCREEN KEEPER SCREW. #10 x 3/4" LONG	4 per clip 2 per keeper		"O" PANEL CLIP	2 per "O" panel
	Screw used to attach the fixed panel clip to the panel. Also used to attach the screen keeper to the main frame jamb.			An aluminum clip that attaches to the panel stile & mainframe jamb. Used to fix the "O" panel in place.	
	JAMB BUMPER SCREW #6 x 3/8" LONG	1 per bumper		SCREEN LATCH KEEPER	1 per operable screen
	Screw used to attach the jamb bumper to the main frame jamb.			Screen latch keeper is used with the standard panel pull on the box screen. Attaches to the mainframe jamb to allow the screen to lock in to the jamb.	
	"O" PANEL PAINTED CLIP SCREW #8 x 1/2" LONG SQUARE DRIVE	4 per clip		ROLLER ADJUST HOLE PLUG	2 per panel
	Screw used to attach the panel clip to the main frame.			Round plug used to fill the hole for the adjustment screw on the rollers.	
	COME - A - LONG SCREW #8 x 3/4" LONG	2 per come - a - long		JAMB BUMPER	1 per main-frame jamb
	Screw used to attach the come -a- long block to each operable panels.			Attached to the mainframe jamb. It keeps the panel from making contact with the mainframe.	
	4 HOLE BUMPER STOP SCREW #8 x 3/8" LONG	4 per bumper		OPEN CELL FOAM PAD	1 per weep
	Screw used to attach the 4 hole bumper stop to sill and head.			Placed in the middle track behind each weep hole slot on the mid sill cover. To help prevent water and air infiltration.	
	COME - A - LONG	2 per operable panel		DUST PLUG (HIGH)	8 at each interlock connection
	Used on the top / bottom of operable panels at interlock. Used on multi panel configurations only.			Used on the main frame at the top / bottom of every operable panel interlock connection.	

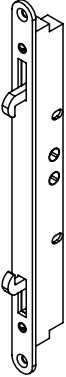
# 680/780 Parts List

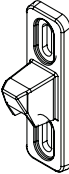
PARTS			
DESCRIPTION	PARTS BAG QTY.		
 <p><b>MORTISE LOCK HANDLE SET (ACTIVE)</b></p> <p>Used to close &amp; lock the door. Handle set comes complete with two metal handles, one on the interior with the thumb lock &amp; the other on the exterior and color match assembly screws.</p>	1 per lockstile panel		
 <p><b>MORTISE LOCK HANDLE SET (INACTIVE)</b></p> <p>Handle set installed on astragal panels. Comes complete with two metal handles, one on the interior, one on the exterior with color match screws.</p> <p>Not used on OXO configurations.</p>	1 per astragal		
 <p><b>MORTISE LOCK KEEPER</b></p> <p>The lock keeper is placed on the mainframe jamb or the astragal. This allows the panel to lock into the mainframe or lock into the astragal panel.</p>	1 per Mortise latch		
 <p><b>MORTISE LATCH</b></p> <p>Factory installed dual point Mortise Latch used to lock the doors.</p>	1 per Mortise latch		
		 <p><b>SCREEN KEEPER SPACER</b></p> <p>Shim used to raise screen keeper off of frame for additional adjustment.</p>	1 per screen keeper
		 <p><b>SCREEN LATCH KEEPER</b></p> <p>Screen latch keeper is used with the standard panel pull on the box screen. Attaches to the mainframe jamb to allow the screen to lock in to the jamb.</p>	1 per screen lockstile
<p><b>BAG MAY BE SENT WITH EXTRA PARTS TO ACCOUNT FOR LOSS OR MISPLACEMENT OF SMALL PIECES.</b></p>			
<p><b>PLEASE MAKE SURE PRIOR TO ASSEMBLY THAT YOU HAVE THE CORRECT AMOUNT OF PARTS CALLED OUT FOR BY THE "PARTS BAG QTY" SECTION.</b></p>			

# NOTICE

CAREFULLY FOLLOWING THE INSTRUCTIONS IN THE PROPER SEQUENCE WILL REDUCE MISTAKES AND SAVE TIME.

- Protect mainframe only with light coating of oil, grease or soap. Action of lime in plaster can destroy finish.
- Sill must be smooth ... buff edges and fill any valleys left by mason. A ridge or lump could cause latching problems.
- If installed in wood surround, measure assembled door frame, add shim space and make surround to these dimensions.
- A Parts List is provided at the front of this document for quick reference. Inspect the product and take inventory of all parts and pieces prior to installation. (ex. screws, frame, panel, etc.)
- Exploded View Reference(s) at the front of this document act as a reference for general location of parts and depict figures that are referenced when following steps outlined in these instructions.
- Carefully review these assembly instructions along with installation details contained in the AAMA Specifications, Miami-Dade Notice of Approval, or test reports, including anchorage information, if applicable.

## SECTION 1: FRAME ASSEMBLY BY-PASS

(if pocket door skip to pocket section)

1. Start by applying the sill adapter to the mainframe sill, it will need to be tapped into place with a plastic or rubber mallet. Place sealant along the edge where the two extrusions will overlap. (See Figure 1)

2. Set the track on an even, flat, fully supported surface and then gently tap the sill riser onto the sill.

**Note:** Do not apply to much pressure as it could bend the track.

3. Assemble mainframe using the supplied # 8 x 1" Phillips pan head screws at each assembly hole. (See Figure 2)

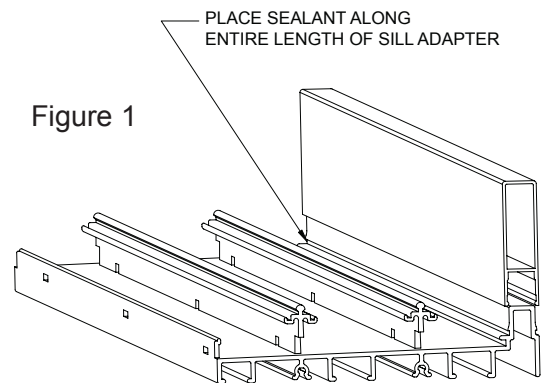

Figure 1

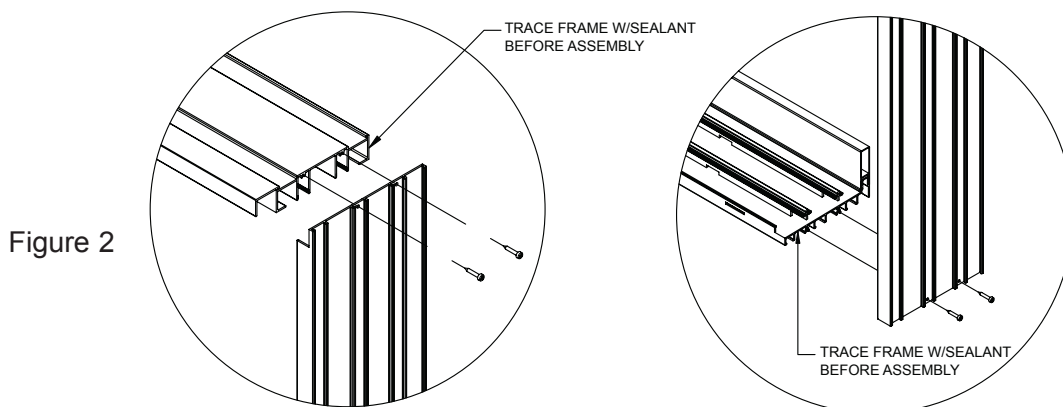

Figure 2

1. Seal under entire length of sill and all frame seams. Make sure to include where the frame sill and head meet the mainframe jambs. (See Figure 3)

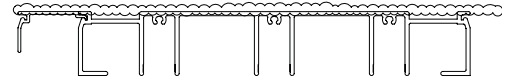

Figure 3

2. Set frame in opening and shim as necessary to make frame plumb, level, and square. Shim behind all frame jamb and header installation screws and near mortise keeper to prevent frame distortion when installation screws are tightened.

**Note:** Frame head, jamb, and track must be level, square, and frame jamb must be plumb at jambs. Measure at head, sill, and midpoint horizontally to be certain that frame is not bowed. Measure from top to bottom across the entire frame from left to right to make sure there are no rises in the sill or dips in the header. Rises in the sill or dips in the header could prevent the panels from being installed. Do not over tighten frame installation screws, this could warp the frame.

(See Figure 4)

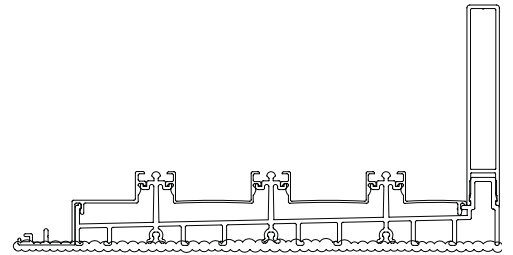

Figure 4

3. Attach frame to opening per PGT's specifications and in compliance with all local code requirements, Notices of Acceptance, or test reports.

4. Next, install open cell foam pads behind the mid sill cover and sill end weeps. (See Figure 5)

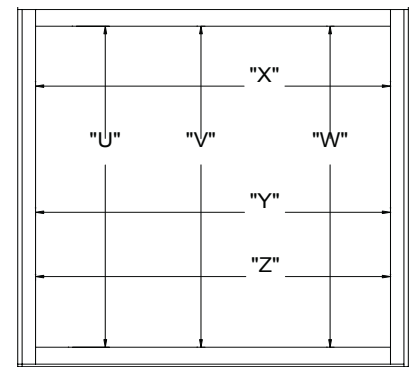
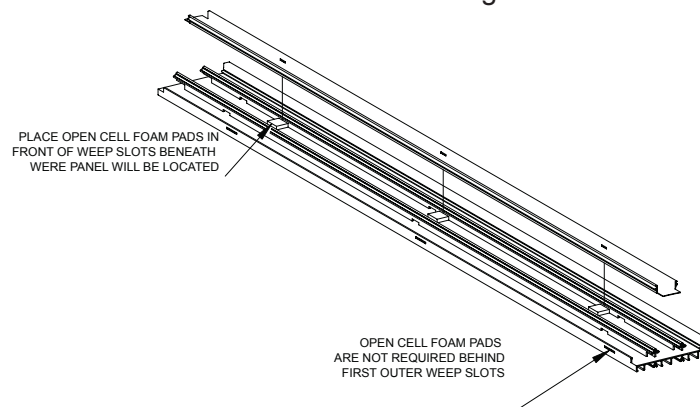

Figure 5



Install fastener covers, (provided), in order as stated below.

There are four different types of sill covers:

- Interior/Exterior sill cover
  - Applied between sill riser and track nearest to the inside.
  - May also be applied to the furthest outside track when a screen rail is not used.
- Mid area sill cover
  - Applied between two consecutive tracks
- Exterior sill cover with attached screen rail
- Main Frame side jamb screw covers
- Main Frame head screw covers

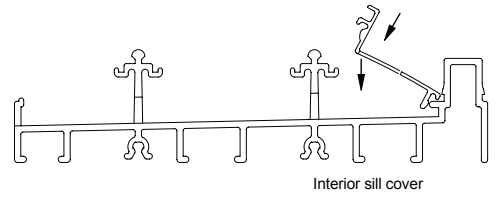

Interior sill cover

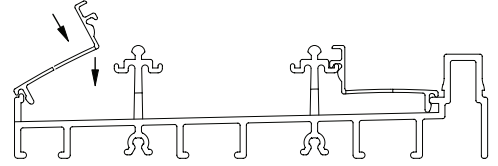

Exterior sill cover without Screen

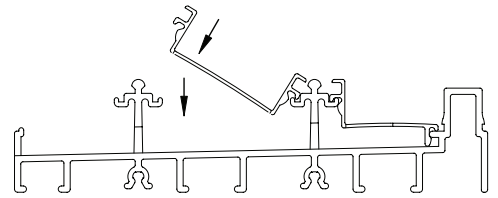

Mid area sill cover

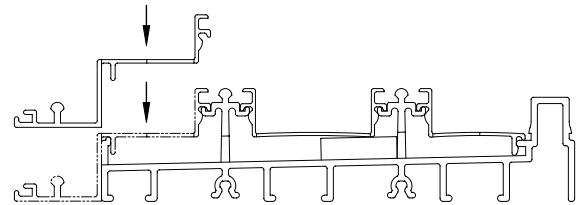

Exterior sill cover with attached screen rail

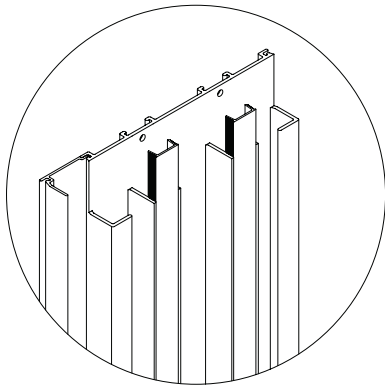

JAMB COVERS

**Note:** Jamb covers sit on top of the panel roller spline and extend up into the main frame header.

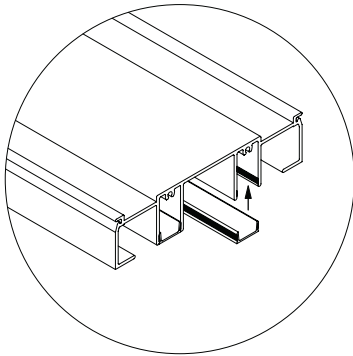

HEAD COVERS

**Note:** Head screw covers fit between the jamb screw covers, on pockets they extend the full length of the track.

## SECTION 2: FRAME ASSEMBLY POCKET DOOR

If unit is not a pocket door skip this and continue on to panel installation.

1. Start by applying the sill adapter to the main frame sill, it will need to be tapped into place with a plastic or rubber mallet. Place sealant along the edge where the two extrusions will overlap. (See Figure 6)

2. Set the track on an even, flat, fully supported surface and then gently tap the sill riser onto the sill.

3. Assemble main frame using supplied # 8 x 1" phillips pan head screws at each assembly hole. (See Figure 7 & 8)

**Note:** Pocket doors will only assemble at head, one jamb, and sill if single pocket. Double pocket main frame is not assembled as there are no jambs supplied with the unit.

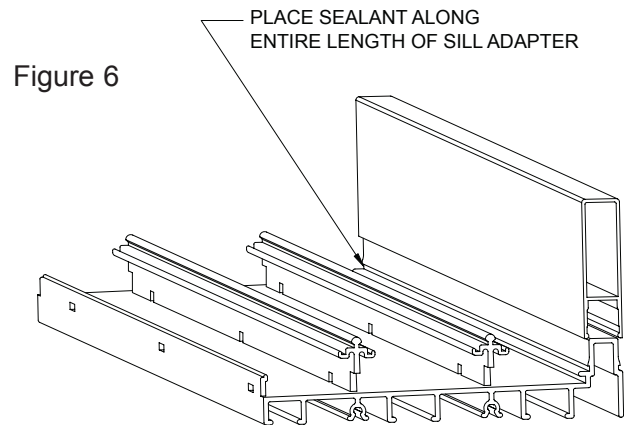

Figure 7

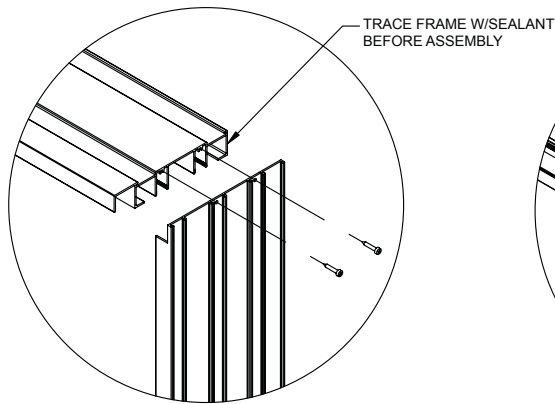
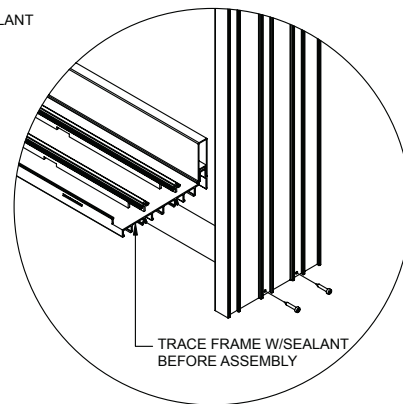

Figure 8



4. Seal under entire length of sill and all frame seams. (See Figure 9)

5. Set frame in opening and shim as necessary to make frame plumb, level, and square. Shim behind all frame jamb and header installation screws and near mortise keeper to prevent frame distortion when installation screws are tightened.

**Note:** Frame head, jamb, and track must be level, square and plumb. Measure at head, track, and latch to be certain that frame is not bowed. Do not over tighten frame installation screws this will warp the frame causing it to prevent the panels from operating properly.

6. Attach frame to opening per PGT's specifications and in compliance with all local code requirements, Notices of Acceptance, or test reports.

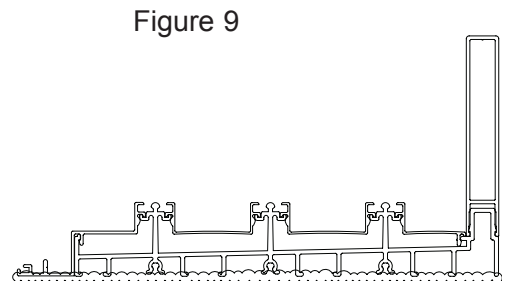
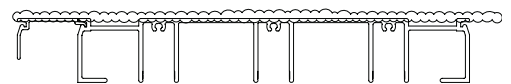

7. Install open cell foam pads behind the weep holes where the panels will be when they are in the closed position. (See Figure 10)

See configuration page for panel orientation.

8. Install fastener covers, (provided), in order as stated below. There are several different types of covers:

- Interior/Exterior sill cover
  - Applied between sill riser and track nearest to the inside.
  - May also be applied to the furthest outside track when a screen rail is not used.
- Mid area sill cover
  - Applied between two consecutive tracks
- Main Frame side jamb screw covers
- Main Frame head screw covers

**Note:** Jamb covers sit on top of the panel roller spline and extend up into the main frame header.

**Note:** Head screw covers fit between the jamb screw covers and extend the entire length of the track.

**Note:** Install fastener covers before installing hook strip.

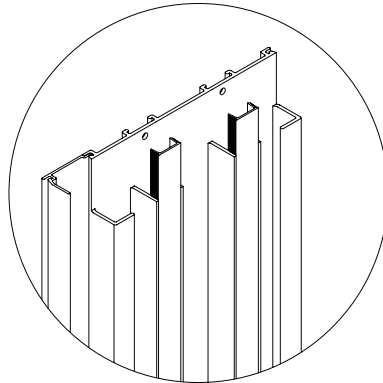

JAMB COVERS

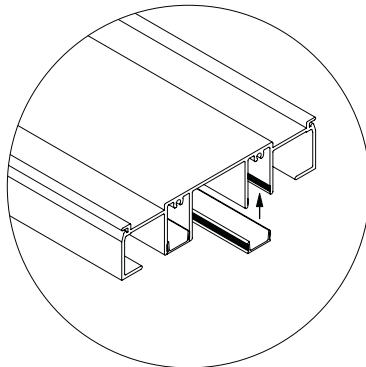

HEAD COVERS

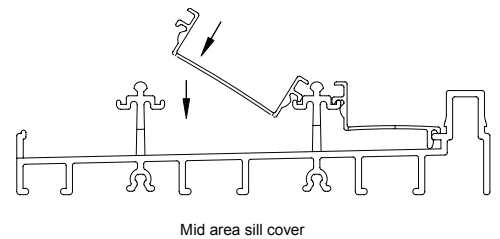
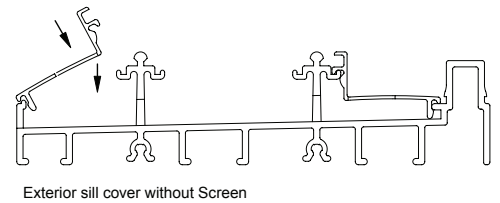
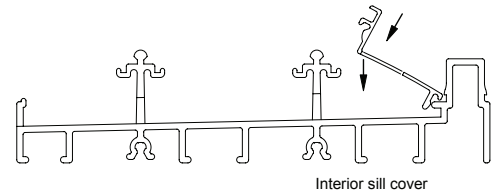
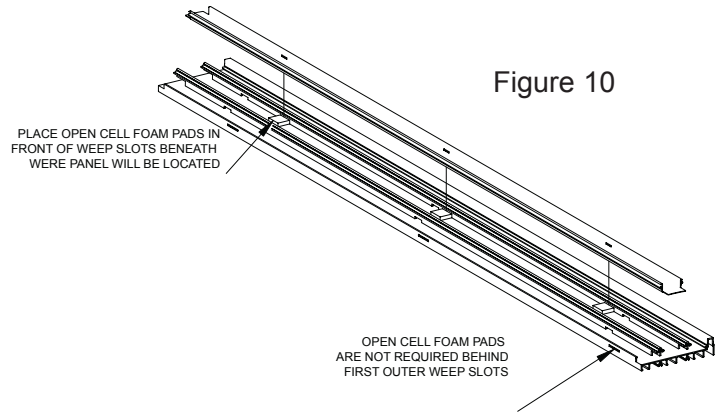



**9.** Hook strip/P-hook will attach interior panels to substrate. Attach frame and hook strip to opening as per PGT's specifications and in compliance with all local code requirements, Notices of Acceptance, or test reports. (See Figure 11)

**Note:** A panel may be needed to properly set the hook strip into place.

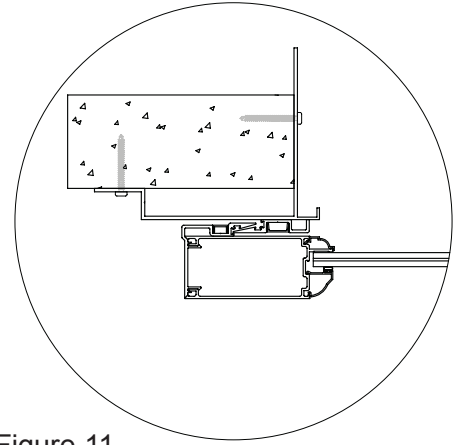
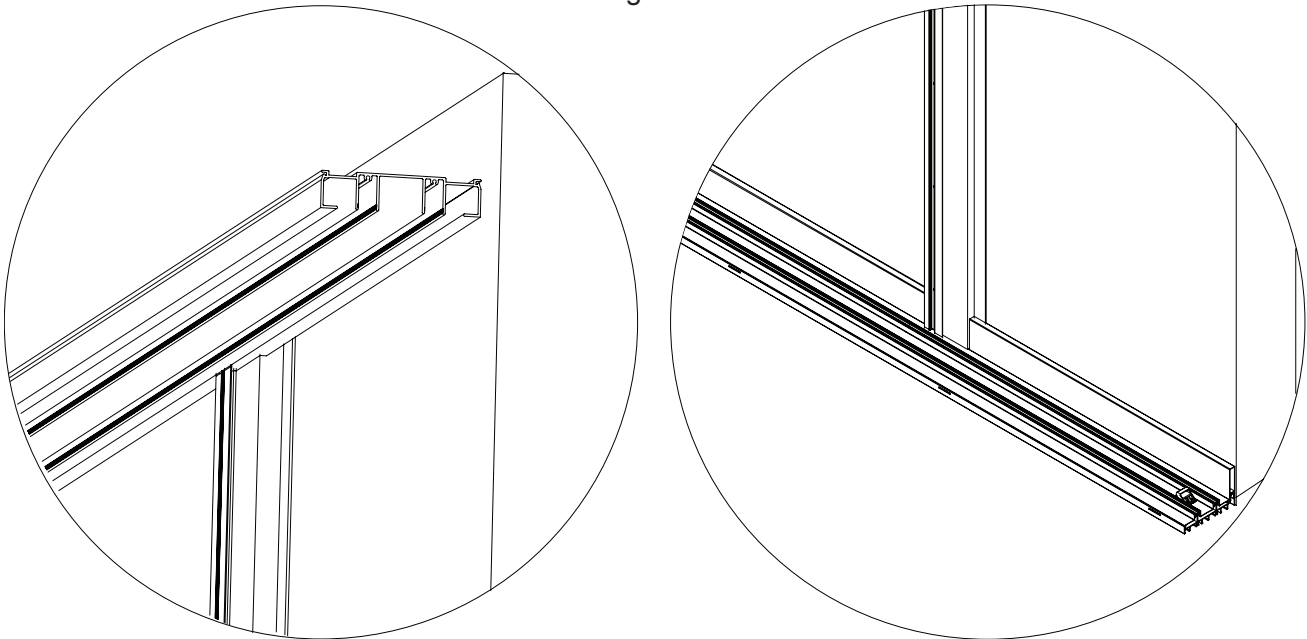

Figure 11

**10.** Hook strip/P-hook sits on top of sill and underneath header. The Hook strip/P-hook is notched to sit over the sill riser. (See Figure 12)

Figure 12



## SECTION 3: PANEL INSTALLATION

PGT offers many sliding glass door configurations; please see the panel orientation sheet to make sure you have the correct panels on the correct tracks.

Shipping labels on panels will have the panel number and letter name on them; they will be installed in order from left to right. Please see the configuration page for the proper track the panel goes onto. (See Figure 13)

1. Position panel so the top of panel slips into the frame header channel. Swing bottom of panel in until bottom of panel is aligned over sill channel and set panel on roller spline. (See Figure 14)

2. Repeat procedure, with next outer panel until all panels are installed.

3. Panels are always installed with roller adjustment holes to the exterior.

4. To adjust rollers on panels use a phillips head screwdriver to turn adjustment screws located on the bottom outside of panel. (See Figure 15)

Figure 13

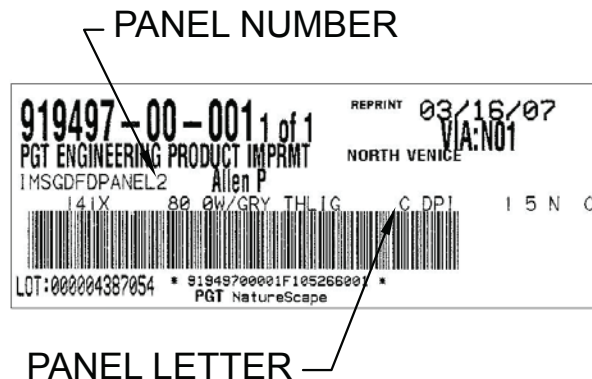

Figure 14

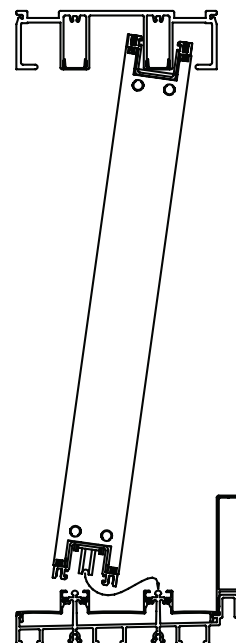
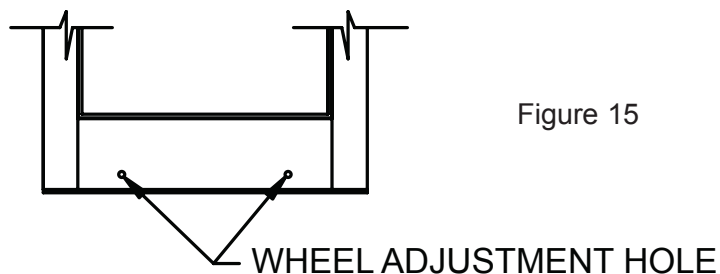

Figure 15



Screw guns can strip the adjustment screws and therefore are not recommended. To raise panels, pick up the panel at the edge to relieve the weight pressure on the wheels, then adjust by turning adjustment screw **CLOCKWISE**. To lower panels turn adjustment screws **COUNTERCLOCKWISE** then use weight pressure on the panel to set the wheels to the new adjustment level.

**WARNING:** When raising and lowering the wheels, if you feel pressure do not continue as this could cause the adjustment screw to strip. Adjust each panel until all panels roll freely and all panel stiles and frame jambs are parallel when in the closed position. (See Figure 16)

5. Once all panels are set into place and have been adjusted properly, check the reveals and operation to verify that everything is in proper working order. You are now ready to start installing the hardware.

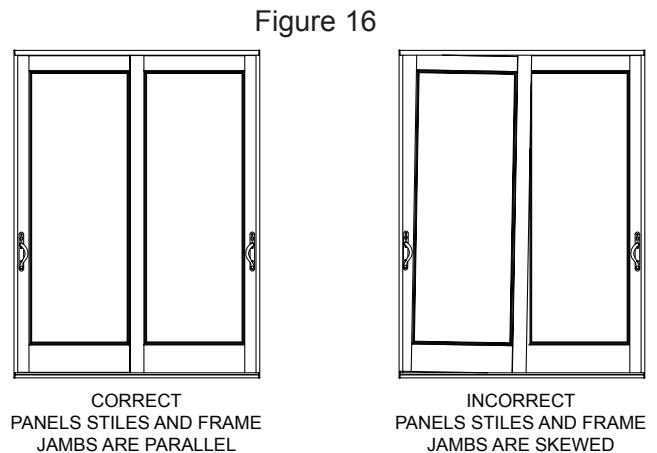

**HELPFUL TIP:** If you have any non-moving panels in your configuration then proceed to fixed panel hardware section. If not, skip to the locking hardware section.

## SECTION 4: FIXED PANEL HARDWARE

The fixed panel clip will be color matched to the frame. Attach the clip to the panel first. Open the panel and screw the clip to the panel with the supplied #10 x  $\frac{3}{4}$  self drilling screw. After attaching the clip to the panel, slide the panel into the closed position and attach the clip to the mainframe. It will be mounted so that the short leg can be attached to the main frame jamb with the #8 x  $\frac{1}{2}$  self drilling screw. (See Figure 17)

If the unit is an OXO configuration then the clip gets installed differently. For the OXO units the fixed panel clip #10 x  $\frac{3}{4}$  self drilling screw is installed into the cavity of the fixed panel clip and the #8 x  $\frac{1}{2}$  self drilling screw attaches the clip to the door panel. (See Figure 18)

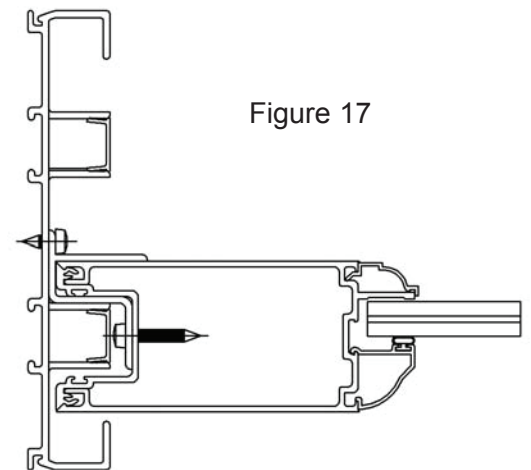
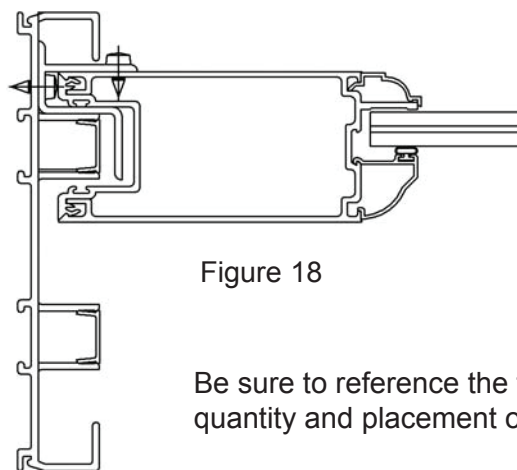

Be sure to reference the test report or Notice Of Acceptance for proper quantity and placement of the fixed panel clips.

## SECTION 5: LOCKING HARDWARE

### Door to Door Connection

- Align the thumb turn tail piece of the interior handle into the slot of the mortise assembly.
- Attach handles using the three #8-32 x 2 ¼" pan head screws provided. (See Figure 19)

**Note:** Latch may not be operated unless latch release pin (located between the 2 mortise cams) is depressed. (See Figure 21 on next page)

## SECTION 6: KEEPER INSTALLATION

- Attach keeper to panel jamb using one of the four #10 X 1 ½" Oval Head screws provided into pre drilled hole in frame jamb.
- With the lock latch extended, adjust the keeper to maximize bite with the latch. Check operation of the lock and adjust the keeper up or down if required.
- Install the three remaining #10 x 1 ½" pan head screws. (See Figure 19)

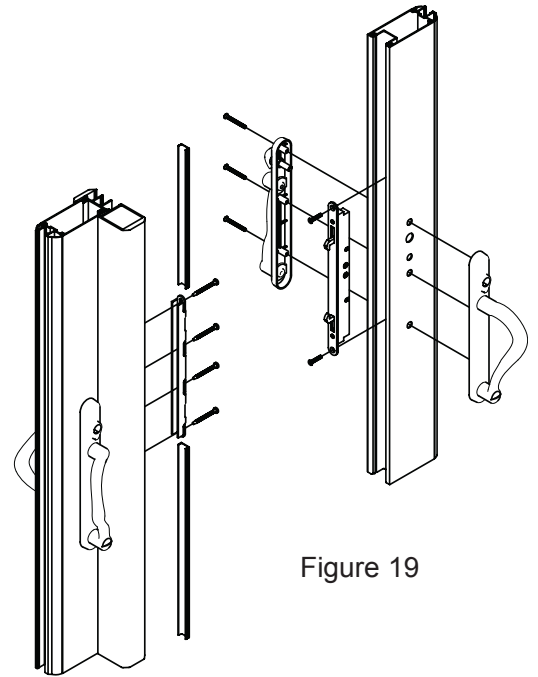

Figure 19

## SECTION 7: LOCKING HARDWARE

### Door to Main Frame Jamb Connection

- Align the thumb turn tail piece of the interior handle into the slot of the mortise assembly.
- Attach handles using the three #8-32 x 2 ¼" pan head screws provided. (See Figure 20)

**Note:** Latch may not be operated unless latch release pin (located between the 2 mortise cams) is depressed. (See Figure 21)

## SECTION 8: KEEPER INSTALLATION

- Attach keeper to frame jamb using one of the four #10 X 1 ½" Oval Head screws provided into pre drilled hole in frame jamb.
- With the lock latch extended, adjust the keeper to maximize bite with the latch. Check operation of the lock and adjust the keeper up or down if required.
- Install the three remaining #10 x 1 ½" pan head screws.
- Check the alignment of the interlocks when in the closed and locked position. (See Figure 20)

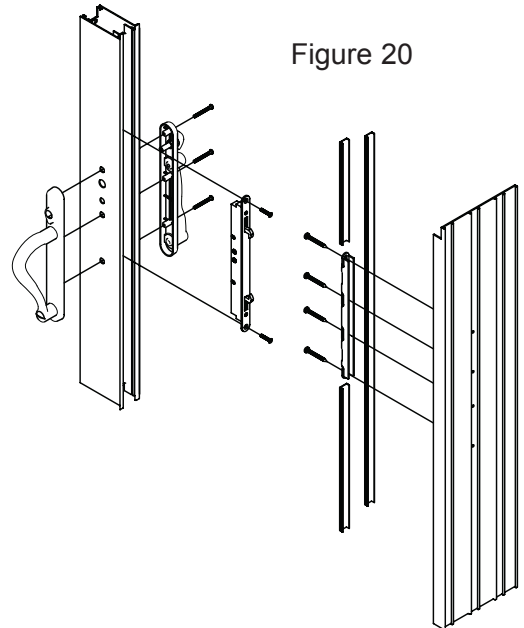

Figure 20

**Note:** There is adjustment on the latch to move the cams in or out. Adjust the cams independently to remove play or add play to the latch engagement in the panel. (See Figure 21)

Figure 21

**Note:** If handleset has a key lock, you will need to open the hole opposite the thumbturn tail piece to 5/8".

## SECTION 9: SCREEN FRAME INSTALLATION

**Note:** Screen mainframe will be separate from panel mainframe when exceeding 2 tracks. If your unit is a 2P2T, 3P2T, 4P2T this will not effect you, skip to the next section. If the unit does not have screens, please skip to the next section.

### Screen Frame Assembly (When not Integral)

1. The screen frame jambs must be installed first to the mainframe jamb. The screen jambs interlock to the mainframe jamb. Insert tail piece and rotate out. (See Figure 22)

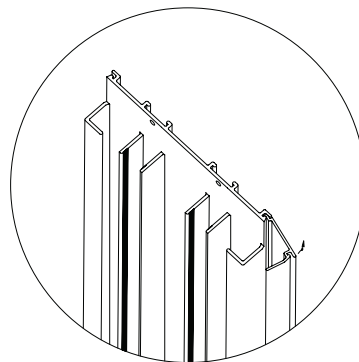

Figure 22

JAMB ADAPTER

2. After screen jambs are in place screen rail sill adapter is attached to glass panel mainframe. Interlock tail piece and rotate down. (See Figure 23)

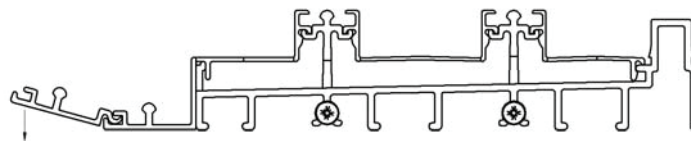
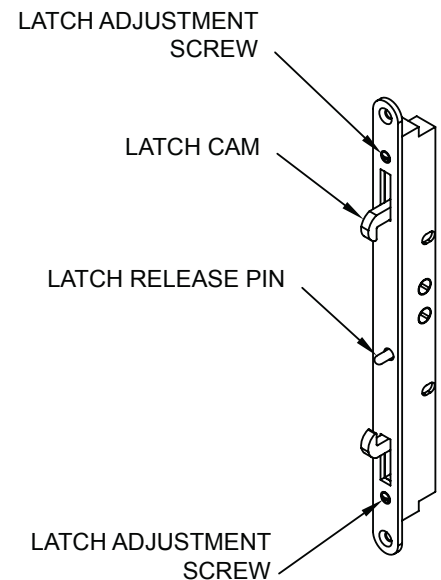

Figure 23

SILL ADAPTER



3. Interlock the screen mainframe head with the glass panel mainframe head. (See Figure 24)

(Figure 24)

4. Attach screen mainframe head to substrate as needed.

**Note:** There are no installation holes prepped on the screen frame extrusion. There are no anchorage requirements for code so space them as needed.

5. Seal under entire length of sill and all frame seams and also apply a small amount of sealant where screen mainframe and glass door main frame meet. (See Figure 25)

6. Shim as necessary to make frame plumb, level, and square. Shim behind all frame jamb and header installation screws and near standard keeper to prevent frame distortion when installation screws are tightened.

**Note:** Frame head and track must be level and frame jamb must be plumb at jambs. Measure at head, track, and latch to be certain that frame is not bowed. Do not overtighten frame installation screws this will warp the frame and prevent the screen(s) from operating properly.

**Note:** If unit is an OXO then the screen astragal adapter and screen astragal will need to be installed. It will be installed at the end of the installation and is in the parts and pieces section of this assembly instruction manual.

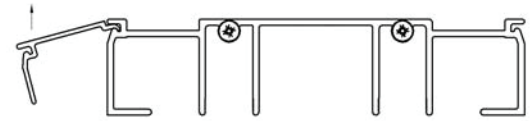

HEAD ADAPTER

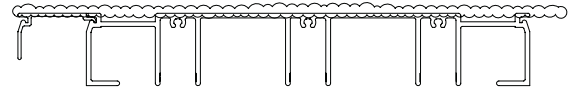

(Figure 25)

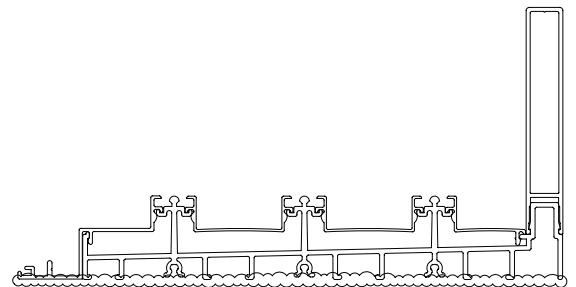

## SECTION 10: SCREEN PANEL INSTALLATION

1. Position panel so that top of panel slips into frame header channel. Swing bottom of panel in until bottom of panel is aligned over sill spline and set panel on roller spline. (See Figure 26)

Repeat procedure, with next outer screen until all screens are installed. Please see the configuration page for the track the screens go on.

**Note:** Plastic interlocks may need to be notched in order for screen panel to fit in frame. Notch accordingly so as not to leave any large gaps.

**Warning:** When raising and lowering the wheels, if you feel pressure do not continue as this could cause the adjustment screw to strip. Adjust each screen until all screens roll freely and all screen stiles and frame jambs are parallel. When screens are properly adjusted, latch keepers may be installed and raised or lowered to make proper contact with latch P-cam.

### Parts and Pieces

After the above steps have been completed, the unit is operating properly, and is set in place you are ready for the final parts and pieces. Such as:

#### High Pile dust plugs:

Dust plugs are used to fill any voids where interlocking panels are set in the closed position and require a weather seal. Position 4 high pile pads above and below the interlocking section of the doors in the closed position. To do this mark the area where the doors interlock together in the closed position. Then open the panels and place the high pile pads on the extrusion making sure that the adhesive backing makes good contact to the extrusion. (See Figure 27)

(Figure 27)

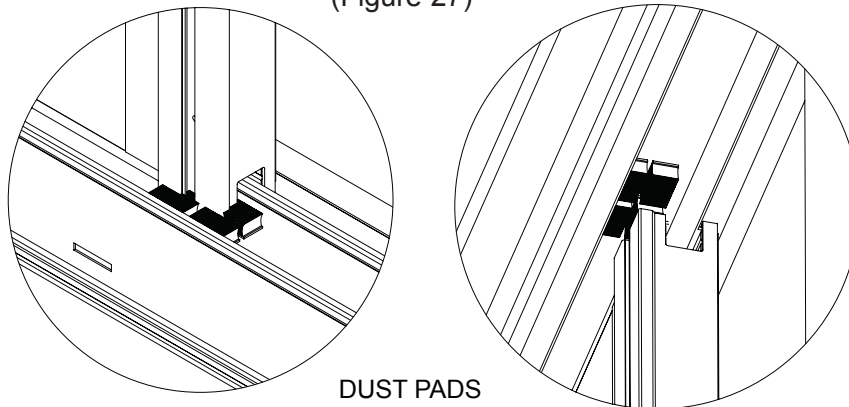

**Note:** It may be necessary to clean the surface that you are applying the adhesive high pile dust pads to if they have debris or cutting oils on them. You want to apply the pads to a dry clean surface.

On some configurations you may have to mark the track and then remove the panels to get the pads into place.

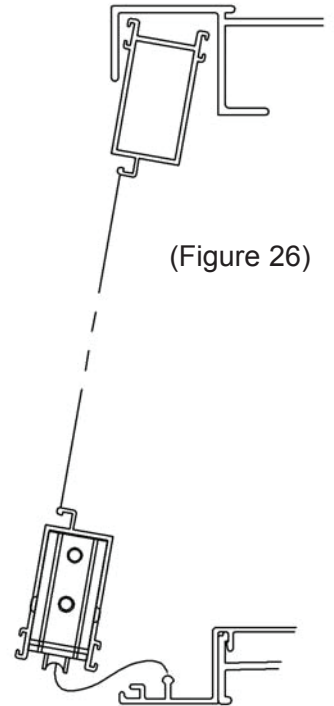

(Figure 26)

## SECTION 11: PANEL BUMPERS

The 4 hole bumper stop can be used to stop the travel of a panel on a bypass or to keep a panel from rolling off the track when installing a pocket door. For a bypass it should be placed on the sill screw cover adapter in such a way to keep the locking handle from making contact with the next doors interlock. On a pocket door unit it should be installed on the sill screw covers to keep a panel from rolling off of the end of a track. (See Figure 28)

**Note:** For multiple panel units it may be necessary to also use the panel come-a-long in conjunction with the 4 hole bumper stops.

(Figure 28)

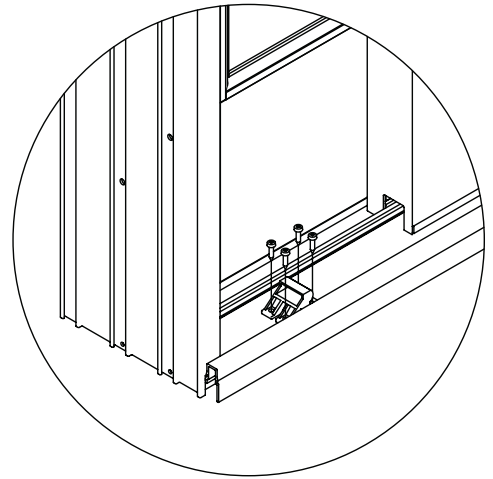

## SECTION 12: PANEL COME-A-LONG

If the unit is a multi-panel, multi-tracked, or pocket door unit you may install panel come-a-longs. This will allow the door to open without having to move each panel individually and also keep the panels from hitting the interlocks or making contact with the handle hardware. They may be installed at the top/bottom or both on the door panel. (See Figure 29)

The Come-a-long should be located in front of the vertical stile at the top and/or bottom rail. As the panel moves down the track it will make contact with the panel come-a-long and start driving the next panel down the track. It installs with two number 8" x 1" sheet metal screw (square drive). When located in the correct position it should leave a gap of 1 7/8" between the handle and the interlock of the panel. (See Figure 30)

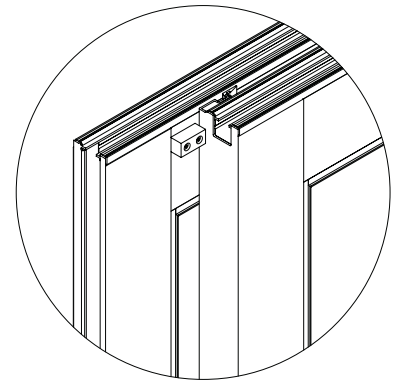

(Figure 29)

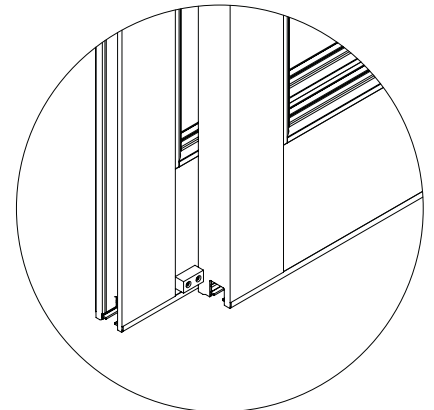

(Figure 30)

1 7/8"

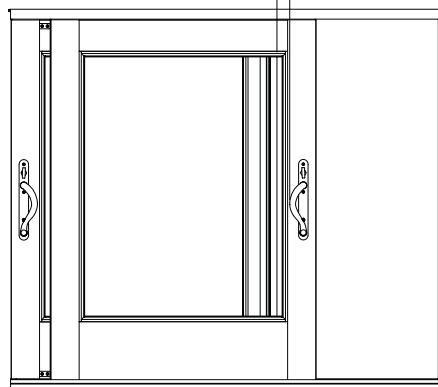

**Note:** Do not locate the part in any other area than shown in the drawing, doing so could cause damage to the frame or glass. Do not use longer screws. Doing so could cause interference or operational problems.



## Adjustment Hole Plug

Once the doors are installed and working properly, you may install the roller adjustment hole plugs. There are two per operable panel and should be located on the outside face of the door. (See Figure 31)

## Screen Astragal and Screen Astragal Adapter:

If the unit has screens and is an OXO configuration, then the screen astragal and screen astragal adapter will need to be installed. Slide the screen astragal into the screen astragal adapter.

Take the assembled part and install it onto the astragal base. This is applied to the exterior of the stationary panel's astragal base as shown in the drawing. (See Figure 32)

Use four screws #10 x $\frac{3}{4}$ " self drilling to attach the astragal adapter and astragal to the glass panels astragal base.

Once installed latch keepers may be installed and raised or lowered to make proper contact with latch P-cam. Caulk any seams where the astragal adapter and astragal meets head or sill.



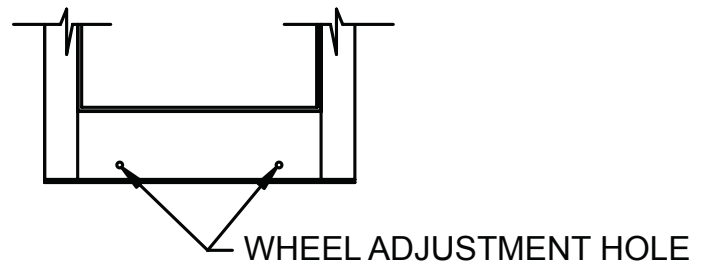



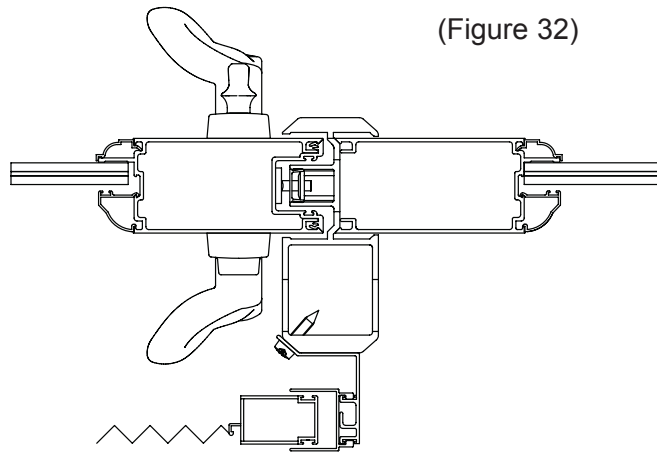

(Figure 31)











(Figure 32)

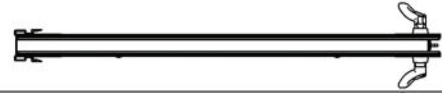

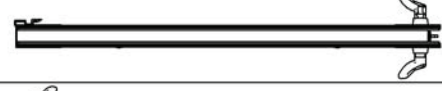

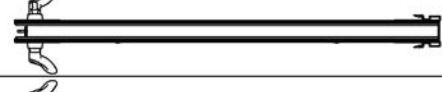

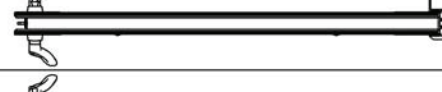

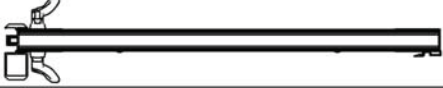

# FIXED - PANEL TYPES

PANEL LETTER			
<b>P</b>	SINGLE INTERLOCK		FIXED LOCKSTILE
<b>R</b>	FIXED LOCKSTILE		SINGLE INTERLOCK
<b>T</b> (BOX OUT)	ASTRAGAL OUT		FIXED LOCKSTILE
<b>T</b> (BOX IN)	ASTRAGAL IN		FIXED LOCKSTILE
<b>S</b> (BOX OUT)	FIXED LOCKSTILE		ASTRAGAL OUT
<b>S</b> (BOX IN)	FIXED LOCKSTILE		ASTRAGAL IN
<b>Y</b>	FIXED LOCKSTILE		DOUBLE INTERLOCK
<b>YR</b>	DOUBLE INTERLOCK		FIXED LOCKSTILE

# OPERABLE - PANEL TYPES

PANEL LETTER			
<b>K</b>	SINGLE INTERLOCK		LOCKSTILE
<b>GR</b>	DOUBLE INTERLOCK		LOCKSTILE
<b>U</b> (BOX OUT)	ASTRAGAL OUT		LOCKSTILE
<b>U</b> (BOX IN)	ASTRAGAL IN		LOCKSTILE
<b>A</b>	SINGLE INTERLOCK		LOCKSTILE
<b>D</b>	LOCKSTILE		SINGLE INTERLOCK
<b>G</b>	LOCKSTILE		DOUBLE INTERLOCK
<b>J</b> (BOX OUT)	LOCKSTILE		ASTRAGAL OUT
<b>J</b> (BOX IN)	LOCKSTILE		ASTRAGAL IN
<b>M</b>	LOCKSTILE		SINGLE INTERLOCK

PANEL LETTER			
<b>W</b> (BOX IN)	DOUBLE INTERLOCK		ASTRAGAL IN
<b>WR</b> (BOX OUT)	ASTRAGAL OUT		DOUBLE INTERLOCK
<b>L</b> (BOX OUT)	SINGLE INTERLOCK		ASTRAGAL OUT
<b>LR</b> (BOX OUT)	ASTRAGAL OUT		SINGLE INTERLOCK
<b>N</b> (BOX OUT)	ASTRAGAL IN		SINGLE INTERLOCK
<b>C</b> (BOX IN)	SINGLE INTERLOCK		ASTRAGAL IN
<b>B</b>	SINGLE INTERLOCK		SINGLE INTERLOCK
<b>F</b>	SINGLE INTERLOCK		SINGLE INTERLOCK
<b>E</b>	SINGLE INTERLOCK		SINGLE INTERLOCK
<b>I</b>	DOUBLE INTERLOCK		DOUBLE INTERLOCK

TYPE	STANDARD	REVERSE	DOUBLE INTERLOCK STANDARD	DOUBLE INTERLOCK REVERSE
2P3T XX BOX SCREEN				
3P3T OXO BOX SCREEN			N/A	N/A
3P4T XXX BOX SCREEN				
3P5T XXX BOX SCREEN				
4P3T OXOX BOX SCREEN		SAME AS STANDARD STACK	N/A	N/A
4P5T XXXX BOX SCREEN				
4P7T XXXX BOX SCREEN				

TYPE	STANDARD	DOUBLE INTERLOCK STANDARD
6P5T XXX XXX BOX SCREEN		N/A
8P7T XXXXXXXX BOX SCREEN		N/A

LEFT HAND POCKETS

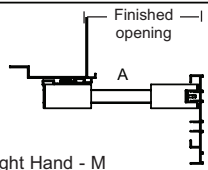

Panel type for Right Hand - M

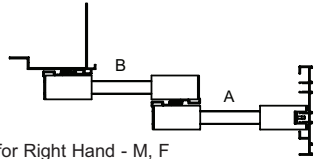

Panel type for Right Hand - M, F

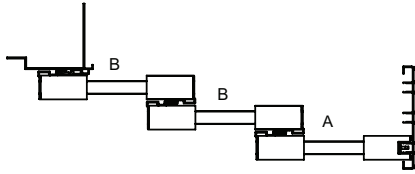

Panel type for Right Hand - M, F, F

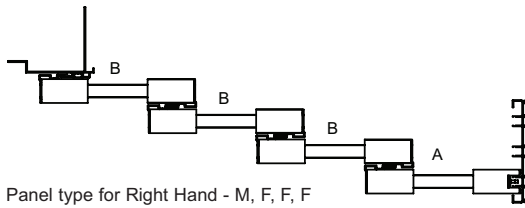

Panel type for Right Hand - M, F, F, F

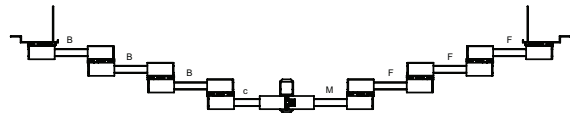
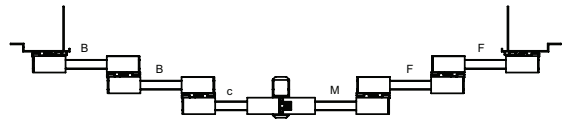
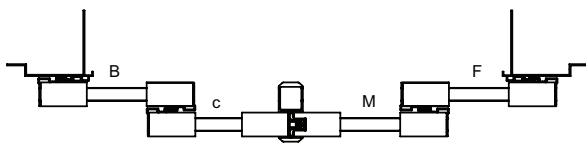
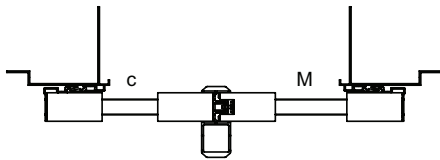





**CUSTOM WINDOWS + DOORS**



PGTINDUSTRIES.COM | N. VENICE, FL  
©2018 PGT CUSTOM WINDOWS + DOORS  
03/2018 MBO200351